

LOCATION MAP

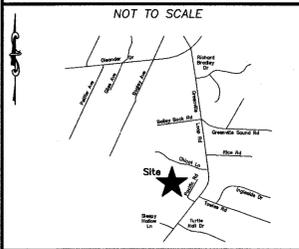

CONSTRUCTION DRAWINGS FOR
PACIFIC PLACE

LOCATED IN CITY OF WILMINGTON
NEW HANOVER COUNTY, NORTH CAROLINA

GENERAL NOTES:

- NEW HANOVER COUNTY PARCEL NUMBERS:
PID = R06212-001-008-000 & R06212-001-002-000
- TOTAL PROJECT AREA: 11.08 AC
- EXISTING ZONING DISTRICT: R-15
- THIS SITE IS LOCATED IN ZONE "X" ACCORDING TO THE FEDERAL EMERGENCY MANAGEMENT AGENCY'S FLOOD INSURANCE RATE MAP, COMMUNITY PANEL NUMBER 37203 15600A, DATED 4/3/06.
- SITE ADDRESS: 6561 GREENVILLE LOOP ROAD
- BOUNDARY AND TOPOGRAPHIC SURVEY PERFORMED BY GEOINNOVATION, PC
6740 NETHERLANDS DR., UNIT A
WILMINGTON, NC 28405
910-799-0099
- VERTICAL DATUM: NAVD 88

WATER			
SIZE	8"	4"	2"
TYPE	C-900	C-900	SDR-21
LF	1,765	-	538

SEWER		
SIZE	8"	8"
TYPE	C-900	DIP
LF	1,458	302

WATER & SEWER USAGE NOTES:

CURRENT WATER USAGE 0 GPD PROPOSED WATER USAGE 14,400 GPD
CURRENT SEWER USAGE 0 GPD PROPOSED SEWER USAGE 14,400 GPD
(40) 3 BEDROOM LOTS X 360 GPD = 14,400 GPD

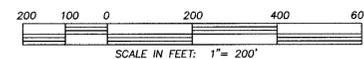
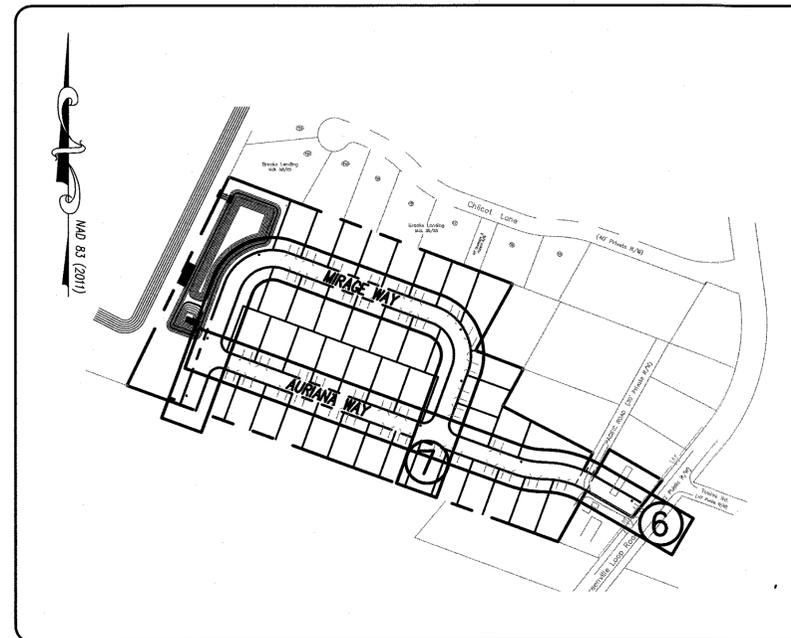

INDEX TO DRAWINGS

SHEET No.	DESCRIPTION	DRAWING No.
1 OF 15	COVER SHEET	CD_COV
2 OF 15	EXISTING BOUNDARY AND TOPOGRAPHY	EX_COND
3 OF 15	TREE INVENTORY	EX_COND
4 OF 15	TREE OVERLAY	TREE-OVERLAY
5 OF 15	SITE PLAN	SP_1
6 OF 15	AURIANA WAY	PP1
7 OF 15	MIRAGE WAY	PP2
8 OF 15	LANDSCAPE PLAN	LP
9 OF 15	CITY OF WILMINGTON STANDARD DETAILS	DET_1
10 OF 15	CITY OF WILMINGTON STANDARD DETAILS	DET_2
11 OF 15	CFPUA STANDARD WATER DETAILS	WSD_1
12 OF 15	CFPUA STANDARD WATER DETAILS	WSD_2
13 OF 15	CFPUA STANDARD SEWER DETAILS	SSD_1
14 OF 15	CFPUA STANDARD SEWER DETAILS	SSD_2
15 OF 15	CFPUA STANDARD SEWER DETAILS	SSD_3

LEGEND

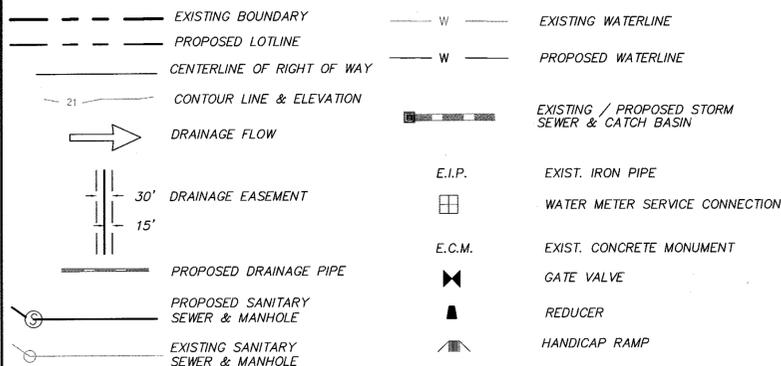

OWNER: ARYA HOLDINGS, LLC
PO BOX 3122
WILMINGTON, NC 28406
910-538-7888

For each open utility cut of City streets, a \$325 permit shall be required from the City prior to occupancy and/or project acceptance.

Approved Construction Plan

Name _____ Date _____

Planning _____

Traffic _____

Fire _____

CITY OF WILMINGTON
NORTH CAROLINA
Public Services • Engineering Division
APPROVED STORMWATER MANAGEMENT PLAN

Date: _____ Permit # _____

Signed: _____

NOTES:

- BOUNDARY AND TOPOGRAPHY SURVEY PERFORMED BY GEOINNOVATION, PC.
- THIS MAP IS NOT FOR CONVEYANCE, RECORDATION, OR SALES.
- THIS PROPERTY IS NOT LOCATED WITHIN A SPECIAL FLOOD HAZARD AREA ACCORDING TO FEMA MAPS.
- THIS PROPERTY IS ZONED R-15
- CFPUA WATER
- CFPUA SEWER
- ALL CONSTRUCTION TO CONFORM TO NEW HANOVER COUNTY STANDARDS AND APPLICABLE STATE & LOCAL CODES.
- CONTRACTOR TO COORDINATE ANY REQUIRED TRAFFIC CONTROL WITH CITY OF WILMINGTON AND OR NCDOT.
- CARE SHALL BE TAKEN DURING FINAL GRADING TO ENSURE POSITIVE DRAINAGE AWAY FROM BUILDINGS AND TO RECEIVING STRUCTURES. ROOF DRAIN DOWNSPOUTS TO BE CONNECTED TO STORM DRAINAGE STUBOUTS OR DIRECTED TO STREET/PARKING AREAS.
- CONTRACTOR IS RESPONSIBLE FOR COORDINATION OF ANY RELOCATIONS, RE-ALIGNMENTS, DISCONNECTIONS OR CONNECTIONS OF EXISTING UTILITIES WITH APPLICABLE AUTHORITIES.
- CLEARING AND GRUBBING OF SITE TO INCLUDE REMOVAL OF EXISTING CURB, ASPHALT, INLETS, AND ANY OTHER STRUCTURES INCLUDING TREES, STUMPS AND DEBRIS EXISTING ON SITE. TREES NOT REQUIRED TO BE CLEARED FOR CONSTRUCTION SHALL REMAIN UNLESS OTHERWISE DIRECTED.
- INFORMATION CONCERNING UNDERGROUND UTILITIES WAS OBTAINED FROM AVAILABLE RECORDS. IT SHALL BE THE RESPONSIBILITY OF THE CONTRACTOR TO DETERMINE THE EXACT ELEVATIONS AND LOCATIONS OF ALL EXISTING UTILITIES AT ALL CROSSINGS PRIOR TO COMMENCING TRENCH EXCAVATION. IF ACTUAL CLEARANCES ARE LESS THAN INDICATED ON PLAN, THE CONTRACTOR SHALL CONTACT THE DESIGN ENGINEER BEFORE PROCEEDING WITH CONSTRUCTION. ANY CONDITION DISCOVERED OR EXISTING THAT WOULD NECESSITATE A MODIFICATION OF THESE PLANS SHALL BE BROUGHT TO THE ATTENTION OF THE DESIGN ENGINEER BEFORE PROCEEDING WITH CONSTRUCTION.
- NO CONSTRUCTION IS TO BEGIN BEFORE LOCATION OF EXISTING UTILITIES HAS BEEN DETERMINED. CALL "NC ONE-CALL" AT LEAST 48 HOURS BEFORE COMMENCING CONSTRUCTION.
- CONTRACTOR SHALL ADJUST ALL MANHOLES, VALVE & CURB BOXES TO FINAL GRADE UPON COMPLETION OF ALL CONSTRUCTION. ANY BOXES DAMAGED OR OTHERWISE DISTURBED BY THE CONTRACTOR SHALL BE REPAIRED AT THE EXPENSE OF THE CONTRACTOR.
- THE CONTRACTOR IS RESPONSIBLE FOR CONTROLLING DUST AND EROSION DURING CONSTRUCTION AT HIS EXPENSE. PARKING AREAS SHALL BE WATERED TO CONTROL DUST WHEN ORDERED BY THE ENGINEER.
- NO GEOTECHNICAL TESTING HAS BEEN PERFORMED ON SITE. NO WARRANTY IS MADE FOR SUITABILITY OF SUBGRADE, AND UNDERCUT AND ANY REQUIRED REPLACEMENT WITH SUITABLE MATERIAL SHALL BE THE RESPONSIBILITY OF THE CONTRACTOR.
- CONTRACTOR TO ENSURE THAT PAVEMENT IS PLACED SO AS TO DRAIN POSITIVELY TO THE STREET INLETS AND CATCH BASINS. ALL FUTURE ROOF DRAIN DOWNSPOUTS TO BE DIRECTED TO THE STORM DRAINAGE STUBOUTS.
- CONTRACTOR IS RESPONSIBLE FOR OBTAINING ALL REQUIRED PERMITS.
- THIS PLAN IS FOR SITE GRADING, UTILITIES, SITING, AND DRAINAGE ONLY. SEE BUILDING PLANS FOR DETAILED HOOKUPS TO BUILDINGS, ETC.
- CONTRACTOR AND BUILDER ARE RESPONSIBLE FOR COORDINATING FINISHED FLOOR ELEVATION OF ALL BUILDINGS WITH THE OWNER. ELEVATIONS GIVEN ARE MINIMUM GROUND ELEVATIONS AT THE BUILDING SITE AND DO NOT PURPORT TO BE FINISHED FLOOR. MINIMUM RECOMMENDED FF ELEVATIONS SHOWN ON PLANS.
- AFFECTED NON-MUNICIPAL UTILITIES SHALL BE CONTACTED AND PROVIDED WITH PLANS AND OTHER PERTINENT INFORMATION, WHEN FEASIBLE, TO COORDINATE APPROPRIATE SCHEDULING AND PLACEMENT.
- EXTREME CARE SHALL BE TAKEN TO ENSURE MINIMUM SEPARATIONS AT ALL UTILITY CROSSINGS.
- MINIMUM SEPARATION SHALL BE MAINTAINED AS FOLLOWS:
 - HORIZONTAL SEPARATION OF 10 FEET BETWEEN SANITARY SEWER AND WATER MAINS AND STORM SEWER.
 - WHERE VERTICAL CLEARANCE IS LESS THAN 24" BETWEEN SANITARY SEWER AND WATER OR WHERE SEWER LINE CROSSES ABOVE WATER MAIN, BOTH PIPES SHALL BE DUCTILE IRON PIPE FOR A MINIMUM OF 10' EITHER SIDE OF CROSSING.
 - WHERE VERTICAL CLEARANCE IS LESS THAN 24" BETWEEN SANITARY SEWER AND STORM DRAIN, SANITARY SEWER SHALL BE DUCTILE IRON PIPE FOR A MINIMUM OF 10 FEET EITHER SIDE OF CROSSING.
 - WHERE VERTICAL CLEARANCE IS LESS THAN 12" BETWEEN SANITARY SEWER AND STORM DRAIN, SANITARY SEWER SHALL BE DUCTILE IRON PIPE FOR A MINIMUM OF 10' EITHER SIDE OF CROSSING, AND BRIDGING SHALL BE INSTALLED PER APPLICABLE UTILITY AUTHORITY'S DETAILS.
 - IN NO CASE SHALL THERE BE LESS THAN 18" OF SEPARATION BETWEEN OUTSIDE OF WATER MAIN AND OUTSIDE OF SEWER OR STORM DRAINAGE.
 - MINIMUM COVER OF 36" SHALL BE PROVIDED FOR ALL BURIED WATER MAINS AND SANITARY SEWER MAINS.
- SEE DETAIL SHEETS FOR TYPICAL UTILITIES HOOKUPS.
- ALL SANITARY SEWER MAINS TO BE 8" UNLESS OTHERWISE INDICATED.
- ALL WATER MAINS TO BE 8" UNLESS OTHERWISE INDICATED.
- TWO VALVES ARE REQUIRED AT "T" INTERSECTIONS AND ONE VALVE ON THE WATER LINE TO FIRE HYDRANTS.
- A BLOW-OFF VALVE IS REQUIRED AT THE TERMINUS OF ALL "DEAD END" WATER LINES.



LICENSE # C-2710
ENGINEERING
LAND PLANNING
COMMERCIAL / RESIDENTIAL

P.O. BOX 4041
WILMINGTON, NC 28406
(910) 791-4441

COVER SHEET
PACIFIC PLACE

CONSTRUCTION DRAWINGS for
PACIFIC PLACE
LOCATED IN CITY OF WILMINGTON
NEW HANOVER COUNTY, NORTH CAROLINA
OWNER: ARYA HOLDINGS, LLC
PO BOX 3122
WILMINGTON, NC 28406



REV. NO.	DATE	BY	REMARKS
5	7/26/18	MRB	REVISION FOR CITY STAMPS
4	7/26/18	MRB	ADDED CITY STAMPS
3	9/29/17	MRB	REVISION FOR SPECIAL COMMENTS, REVISION ROAD MARKS
2	9/29/17	MRB	REVISION FOR SPECIAL COMMENTS, REVISION ROAD MARKS
1	9/29/17	MRB	REVISION FOR SPECIAL COMMENTS, REVISION ROAD MARKS

DATE: 7-12-17
HORIZ. SCALE: 1" = 200'
VERT. SCALE: N/A
DRAWN BY: MRB
CHECKED BY: HSR
PROJECT NO.: 17-0398



CSD ENGINEERING
 LICENSE # C-2710
 ENGINEERING
 LAND PLANNING
 COMMERCIAL / RESIDENTIAL
 P.O. BOX 4041
 WILMINGTON, NC 28406
 (910) 791-4441

EXISTING CONDITIONS for
PACIFIC PLACE

EXISTING CONDITIONS for
PACIFIC PLACE
 LOCATED IN CITY OF WILMINGTON
 NEW HANOVER COUNTY, NORTH CAROLINA
 OWNER: ARYA HOLDINGS, LLC
 P.O. BOX 3172
 WILMINGTON, NC 28406



REV. NO.	DATE	BY	REMARKS
4	5/7/19	MRB	REVISED TO ADD MISSING TREES
3	1/15/18	MRB	REVISED FOR CITY SIGNATURES
2	12/11/17	RLW	REVISED NOTES
1	9/08/17	JSM	SHEET NUMBER REVISED

DATE: 7-12-17
 HORZ. SCALE: 1" = 50'
 VERT. SCALE: N/A
 DRAWN BY: RLW
 CHECKED BY: HSR
 PROJECT NO.: 17-0398
 Sheet No. **2** of **15**



- TOTAL PROJECT AREA: 482,528 SF (11.08 AC.)
- THIS SITE IS LOCATED WITHIN ZONE "X" ACCORDING TO FEMA FIRM COMMUNITY PANEL NUMBER 3720315600L, EFFECTIVE DATE 4/3/06
- AS-BUILT BOUNDARY AND TOPOGRAPHIC SURVEY PERFORMED AND PROVIDED TO CSD ENGINEERING BY GEONNOVATION, PC VERTICAL DATUM = 88
- STORMWATER DRAINS TO BRADLEY CREEK, SC 18-87-24-4(2)

Approved Construction Plan
 Name _____ Date _____
 Planning _____
 Traffic _____
 Fire _____

CITY OF WILMINGTON
 NORTH CAROLINA
 Public Services • Engineering Division
 APPROVED STORMWATER MANAGEMENT PLAN
 Date: _____ Permit # _____
 Signed: _____

For each open utility cut of City streets, a \$325 permit shall be required from the City prior to occupancy and/or project acceptance.

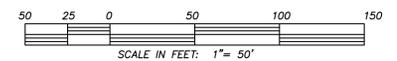

Point #	Raw Description
1	12P
2	12P
3	16P
4	12P
5	17P
6	14P
7	2-6BAYS
8	12P
9	12P
10	16P
11	12P
12	12P
13	12P
14	16P
15	2-6 BAYS
16	14P
17	12P
18	13P
19	12P
20	12P
21	12P
22	13P
23	12P
24	12P
25	18P
26	16P
27	14P
28	16P
29	15P
30	13P
31	7 MAG
32	13P
33	12P
34	13P
35	6 MAG
36	12P
37	12P
38	12P
39	13P
40	17P
41	12P
42	7 MAG
43	16P
44	14P
45	16P
46	12P
47	13P
48	13P
49	17P
50	16P
51	16P
52	12P
53	12P
54	12P
55	12P
56	12P
57	12P
58	12P
59	12P
60	13P
61	12P
62	14P
63	12P
64	12P
65	18P

Point #	Raw Description
66	12P
67	12P
68	11 MAG
69	8 MAG
70	12 MAG
71	9 BAY
72	12P
73	12P
74	12P
75	12P
76	12P
77	12P
78	12P
79	12P
80	14P
81	12P
82	7 BAY
83	6 BAY
84	8 BAY
85	6 BAY
86	12P
87	12P
88	12P
89	12P
90	14P
91	14P
92	13P
93	12P
94	13P
95	13P
96	12P
97	12P
98	22P
99	14P
100	12P
101	14 GUM
102	15P
103	14P
104	12P
105	13P
106	12P
107	15P
108	12P
109	14P
110	12P
111	12P
112	18P
113	11 GUM
114	12P
115	15P
116	12P
117	13P
118	13P
119	13P
120	13P
121	13P
122	13P
123	16P
124	7 MAG
125	12P
126	18P
127	15P
128	14P
129	14P
130	13P

Point #	Raw Description
131	12P
132	13P
133	15P
134	12P
135	12P
136	6 MAG
137	17P
138	12P
139	13P
140	7 OAK
141	12P
142	14P
143	16P
144	12P
145	12P
146	12P
147	12P
148	12P
149	12P
150	16P
151	13P
152	12P
153	12P
154	13P
155	13P
156	12P
157	12P
158	12P
159	12P
160	12P
161	12P
162	14P
163	14P
164	14P
165	14P
166	12P
167	12P
168	12P
169	12P
170	12P
171	12P
172	13P
173	13P
174	17P
175	15P
176	12P
177	12P
178	12P
179	12P
180	13P
181	13P
182	13P
183	12P
184	12P
185	12P
186	12P
187	2- 6 MAG
188	6 MAG
189	14P
190	12P
191	13P
192	13P
193	13P
194	13P
195	13P

Point #	Raw Description
196	13P
197	13P
198	6 MAG
199	12P
200	12P
201	12P
202	12P
203	12P
204	12P
205	12P
206	12P
207	13P
208	12P
209	15P
210	12P
211	12P
212	12P
213	14P
214	7 BAY
215	2 - 7 BAY
216	8 BAY
217	8 BAY
218	2 - 6 BAY
219	2 - 7 BAY
220	11 MAG
221	12P
222	12P
223	12P
224	14P
225	8 OAK
226	4 - 6 BAY
227	22P
228	12P
229	20P
230	12P
231	12P
232	12P
233	12P
234	12P
235	12P
236	10 OAK
237	8 OAK
238	16P
239	15P
240	13P
241	5 MAG
242	12P
243	12P
244	13P
245	12P
246	8 OAK
247	2-6 BAY
248	12P
249	12P
250	12P
251	12P
252	12P
253	3 - 7 BAY
254	8 BAY
255	18P
256	4 - 7 BAY
257	2 - 7 BAY
258	13P
259	14P
260	14P

Point #	Raw Description
261	12P
262	12P
263	12P
264	13P
265	13P
266	18P
267	12P
268	12P
269	12P
270	12P
271	16P
272	6 MAG
273	12P
274	13P
275	13P
276	
277	
278	12P
279	14P
280	14P
281	13P
282	16P
283	18P
284	16P
285	12P
286	15P
287	7 GUM
288	12P
289	15P
290	12P
291	13P
292	13P
293	12P
294	13P
295	13P
296	13P
297	17P
298	13P
299	14P
300	12P
301	12P
302	12P
303	10 GUM
304	8 GUM
305	12P
306	15P
307	17P
308	13P
309	12P
310	12P
311	12P
312	22P
313	12P
314	12P
315	8 OAK
316	8 OAK
317	9 GUM
318	9 GUM
319	11 BAY
320	13P
321	7 BAY
322	12P
323	12P
324	13P
325	12P

Point #	Raw Description
326	12P
327	12P
328	15P
329	12P
330	12P
331	14 OAK
332	14P
333	10 GUM
334	14P
335	14P
336	20P
337	14P
338	7 MAG
339	12P
340	12P
341	20P
342	15P
343	24P
344	10 GUM
345	8 BAY
346	8 BAY
347	12P
348	12P
349	12P
350	16P
351	3 - 7 BAY
352	12P
353	7 BAY
354	13P
355	12P
356	7 BAY
357	8 BAY
358	12P
359	13P
360	3 - 6 BAY
361	12P
362	2 - 12P
363	16P
364	12P
365	7 BAY
366	12P
367	12P
368	12P
369	12P
370	10 BAY
371	12P
372	12P
373	12P
374	12P
375	7 BAY
376	12P
377	18P
378	12P
379	2 - 10 BAY
380	8 BAY
381	2 - 5 BAY
382	12P
383	12P
384	12P
385	12P
386	6 MAG
387	2 - 5 BAY
388	12P
389	12P
390	12P

Point #	Raw Description
391	12P
392	12P
393	12P
394	12P
395	12P
396	12P
397	5 MAG
398	2 - 9 BAY
399	2 - 7 BAY
400	12P
401	12P
402	14P
403	18P
404	13P
405	12P
406	12P
407	12P
408	12P
409	7 BAY
410	13P
411	13P
412	14P
413	12P
414	12P
415	12P
416	8 BAY
417	8 BAY
418	10 BAY
419	10 BAY
420	6 BAY
421	6 MAG
422	2 - 8 BAY
423	2 - 8 BAY
424	8 BAY
425	2 - 8 BAY
426	16P
427	12P
428	14P
429	12P
430	12P
431	12P
432	16P
433	12P
434	22P
435	8 OAK
436	6 BAY
437	6 BAY
438	6 BAY
439	8 BAY
440	8 OAK
441	16P
442	22P
443	12P
444	12P
445	12P
446	12P
447	16P
448	13P
449	18P
450	16P
451	12P
452	12P
453	18P
454	12P
455	12P

Point #	Raw Description
456	15P
457	17P
458	15P
459	15P
460	17P
461	6 BAY
462	14P
463	13P
464	6 BAY
465	12P
466	12P
467	12P
468	6 BAY
469	12P
470	9 MAG
471	11 MAG
472	12P
473	14P
474	14P
475	14P
476	12P
477	8 MAG
478	2 - 12P
479	12P
480	12P
481	12P
482	14P
483	14P
484	12P
485	12P
486	12P
487	12P
488	18P
489	14P
490	12P
491	10 GUM
492	10 OAK
493	9 GUM
494	16P
495	14P
496	13P
497	7 GUM
498	12P
499	14P
500	13 GUM
501	12P
502	12P
503	12P
504	20 OAK
505	12P
506	12P
507	14P
508	13P
509	12P
510	12P
511	14P
512	17P
513	12P
514	16P
515	12P
516	12P
517	12 OAK
518	12P
519	12P
520	14P

Point #	Raw Description
521	12P
522	12P
523	16P
524	8 BAY
525	8 BAY
526	16P
527	12P
528	12P
529	12P
530	2 - 12P
531	12P
532	12P
533	12P
534	26P
535	22P
536	12P
537	16P
538	14P
539	16P
540	20P
541	16P
542	16P
543	12P
544	16P
545	16P
546	13P
547	9 OAK
548	12P
549	12P
550	16P
551	3 - 8 BAY
552	7 BAY
553	18P
554	12P
555	16P
556	13P
557	13P
558	13P
559	12P
5	



LICENSE # C-2710
ENGINEERING
LAND PLANNING
COMMERCIAL / RESIDENTIAL

P.O. BOX 4041
WILMINGTON, NC 28406
(910) 791-4441

TREE OVERLAY for
PACIFIC PLACE

TREE OVERLAY for
PACIFIC PLACE
LOCATED IN CITY OF WILMINGTON
NEW HANOVER COUNTY, NORTH CAROLINA
OWNER: ARYA HOLDINGS, LLC
1005 STEEZ
WILMINGTON, NC 28406

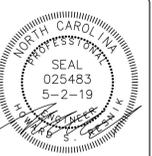

REV.	DATE	BY	REMARKS
7	5/2/19	MSB	REMOVED PER NEW LOT LAYOUT AND TO ADD MISSING TREES
6	1/15/18	MSB	PLOTTED FOR CITY SUBMISSIONS
5	1/16/18	RLW	REVISED TREE PROTECTION AREA
4	12/14/17	RLW	ADDED TREE MITIGATION CALC
3	12/11/17	RLW	REVISED PER TRC COMMENTS
2	10/9/17	MSB	REVISED PER TRC COMMENTS
1	9/28/17	MSB	REVISED PER TRC COMMENTS

DATE: 7-12-17
HORIZ. SCALE: 1" = 50'
VERT. SCALE: N/A
DRAWN BY: RLW
CHECKED BY: HSR
PROJECT NO.: 17-0398

TREES SCHEDULED FOR REMOVAL

Point #	Description	Point #	Description	Point #	Description	Point #	Description	Point #	Description
1	12P	133	15P	233	12P	327	12P	418	10 BAY
2	12P	134	12P	234	12P	328	15P	419	10 BAY
3	16P	135	12P	235	12P	329	12P	420	6 BAY
4	12P	136	6 MAG	236	10 OAK	330	12P	421	6 MAG
5	17P	137	17P	237	8 OAK	332	14P	422	2 - 8 BAY
6	14P	138	12P	238	16P	333	10 GUM	423	2 - 8 BAY
7	2-6 BAYS	139	13P	239	15P	334	14P	424	8 BAY
8	12P	140	7 OAK	242	12P	335	14P	425	2 - 8 BAY
9	12P	141	12P	243	12P	336	20P	426	16P
10	16P	142	14P	244	13P	337	14P	427	12P
11	12P	143	16P	245	12P	338	7 MAG	428	14P
12	12P	144	12P	246	8 OAK	339	12P	429	12P
13	12P	145	12P	247	2-6 BAY	340	12P	430	12P
14	16P	146	12P	248	12P	341	20P	431	12P
15	2-6 BAYS	147	12P	249	12P	342	15P	432	16P
16	14P	148	12P	250	12P	343	24P	433	12P
17	12P	149	12P	251	12P	344	10 GUM	434	22P
18	13P	150	16P	252	12P	345	8 BAY	435	8 OAK
19	12P	156	12P	253	3 - 7 BAY	346	8 BAY	436	6 BAY
20	12P	157	12P	254	8 BAY	347	12P	437	6 BAY
21	12P	158	12P	255	18P	348	12P	438	6 BAY
22	13P	159	12P	256	4 - 7 BAY	349	12P	439	8 BAY
23	12P	160	12P	257	2 - 7 BAY	350	16P	440	8 OAK
24	12P	161	12P	258	13P	351	3 - 7 BAY	441	16P
25	18P	162	14P	259	14P	352	12P	442	22P
26	16P	163	14P	260	14P	353	7 BAY	443	12P
27	14P	165	14P	261	12P	354	13P	444	12P
28	16P	166	12P	262	12P	355	12P	445	12P
29	15P	167	12P	263	12P	356	7 BAY	446	12P
30	13P	168	12P	264	13P	357	8 BAY	447	16P
31	7 MAG	169	12P	265	13P	358	12P	448	13P
32	13P	170	12P	266	18P	359	13P	449	18P
33	12P	171	12P	267	12P	360	3 - 6 BAY	450	16P
34	13P	172	13P	268	12P	361	12P	451	12P
35	6 MAG	173	13P	269	12P	362	2 - 12P	452	12P
36	12P	174	17P	270	12P	363	16P	453	18P
37	12P	175	15P	271	16P	364	12P	454	12P
38	12P	176	12P	272	6 MAG	365	7 BAY	455	12P
39	13P	177	12P	273	12P	366	12P	456	15P
40	17P	178	12P	274	13P	367	12P	457	17P
41	12P	179	12P	275	13P	368	12P	458	15P
42	7 MAG	180	13P	276		369	12P	459	15P
71	9 BAY	181	13P	277		370	10 BAY	460	17P
72	12P	182	13P	278	12P	371	12P	461	6 BAY
73	12P	183	12P	279	14P	372	12P	462	14P
74	12P	184	12P	280	14P	373	12P	463	13P
75	12P	185	12P	281	13P	374	12P	464	6 BAY
76	12P	186	12P	282	16P	375	7 BAY	465	12P
77	12P	187	2 - 6 MAG	283	18P	376	12P	466	12P
78	12P	188	6 MAG	284	16P	377	18P	467	12P
79	12P	189	14P	285	12P	378	12P	468	6 BAY
86	12P	190	12P	286	15P	379	2 - 10 BAY	469	12P
87	12P	191	13P	287	7 GUM	380	8 BAY	470	9 MAG
88	12P	192	13P	290	12P	381	2 - 5 BAY	471	11 MAG
89	12P	193	13P	291	13P	382	12P	472	12P
90	14P	194	13P	292	13P	383	12P	473	14P
91	14P	195	13P	293	12P	384	12P	474	14P
92	13P	196	13P	294	13P	385	12P	475	14P
93	12P	197	13P	295	13P	386	6 MAG	476	12P
94	13P	198	6 MAG	296	13P	387	2 - 5 BAY	477	8 MAG
95	13P	199	12P	297	17P	388	12P	478	2 - 12P
96	12P	200	12P	298	13P	389	12P	479	12P
97	12P	201	12P	299	14P	390	12P	480	12P
98	22P	202	12P	300	12P	391	12P	481	12P
99	14P	203	12P	301	12P	392	12P	482	14P
100	12P	204	12P	302	12P	393	12P	483	14P
101	14 MAG	205	12P	303	10 GUM	394	12P	484	12P
102	15P	206	12P	304	8 GUM	395	12P	485	12P
103	14P	207	13P	305	12P	396	12P	486	12P
104	12P	208	12P	306	15P	397	5 MAG	487	12P
105	13P	209	15P	307	17P	398	2 - 9 BAY	488	18P
106	12P	210	12P	308	13P	399	2 - 7 BAY	489	14P
107	15P	211	12P	309	12P	400	12P	490	12P
108	12P	212	12P	310	12P	401	12P	494	16P
109	14P	213	14P	311	12P	402	14P	495	14P
110	12P	214	7 BAY	312	22P	403	18P	498	12P
112	18P	215	2 - 7 BAY	313	12P	404	13P	502	12P
113	11 GUM	216	8 BAY	314	12P	405	12P	505	12P
121	13P	217	8 BAY	315	8 OAK	406	12P	506	12P
122	13P	218	2 - 6 BAY	316	8 OAK	407	12P	507	14P
123	16P	219	2 - 7 BAY	317	9 GUM	408	12P	508	13P
124	7 MAG	220	11 MAG	318	9 GUM	409	7 BAY	509	12P
125	12P	221	12P	319	11 BAY	410	13P	510	12P
126	18P	223	12P	320	13P	411	13P	511	14P
127	15P	227	22P	321	7 BAY	412	14P	512	17P
128	14P	228	12P	322	12P	413	12P	513	12P
129	14P	229	20P	323	12P	414	12P	514	16P
130	13P	230	12P	324	13P	415	12P	515	12P
131	12P	231	12P	325	12P	416	8 BAY	516	12P
132	13P	232	12P	326	12P	417	8 BAY	517	12 OAK

**DAMAGED BY STORM



TREE MITIGATION CALCULATIONS

POINT	INCHES	TYPE	MITIGATION FACTOR
68	11	MAGNOLIA	100
69	8	MAGNOLIA	100
70	12	MAGNOLIA	100
220	11	MAGNOLIA	100
470	9	MAGNOLIA	100
471	11	MAGNOLIA	100
477	8	MAGNOLIA	100
TOTAL	70		

(TOTAL TBD X 2 X MITIGATION FACTOR)/3
(70 X 2)/3 = 47 TREES

TREE PRESERVATION CALCULATIONS

PRESERVED TREES (INCHES DBH)	CREDIT VALUE	# OF TREES	CREDIT
2-5	1		
6-11	2	11	22
12-17	3	56	168
18-23	4	4	16
>24	DBH/6	1	4.3
TOTAL			210.3

- TOTAL PROJECT AREA: x SF (11.08 AC.)
- THIS SITE IS LOCATED WITHIN ZONE "X" ACCORDING TO FEMA FIRM COMMUNITY PANEL NUMBER 3720315600J, EFFECTIVE DATE 4/3/06
- ASBUILT, BOUNDARY AND TOPOGRAPHIC SURVEY PERFORMED AND PROVIDED TO CSD ENGINEERING BY GEONNOVATION, PC VERTICAL DATUM = 88
- STORMWATER DRAINS TO BRADLEY CREEK, SC 18-87-24-(42)

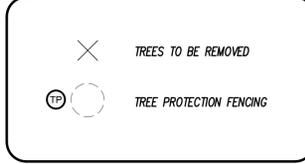

For each open utility cut of City streets, a \$325 permit shall be required from the City prior to occupancy and/or project acceptance.

Approved Construction Plan

Name _____ Date _____

Planning _____

Traffic _____

Fire _____

CITY OF WILMINGTON
NORTH CAROLINA
Public Services • Engineering Division
APPROVED STORMWATER MANAGEMENT PLAN

Date: _____ Permit # _____

Signed: _____



LOCATION MAP

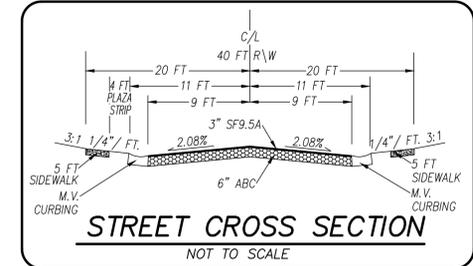
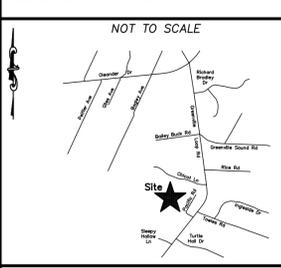

CSD ENGINEERING
 LICENSE # C-2710
 ENGINEERING
 LAND PLANNING
 COMMERCIAL / RESIDENTIAL
 P.O. BOX 4041
 WILMINGTON, NC 28406
 (910) 791-4441

TRAFFIC ENGINEERING NOTES:

- A LANDSCAPING PLAN INDICATING THE LOCATION OF REQUIRED STREET TREES SHALL BE SUBMITTED TO THE CITY OF WILMINGTON TRAFFIC ENGINEERING DIVISION AND PARKS AND RECREATION DEPARTMENT FOR REVIEW AND APPROVAL PRIOR TO RECORDING OF THE FINAL PLAN. PLAN SHALL ADHERE TO SD 15-17.
- TRAFFIC CONTROL DEVICES (INCLUDING SIGNS AND PAVEMENT PARKINGS) IN AREAS OPEN TO PUBLIC TRAFFIC ARE TO MEET MUTCD STANDARDS.
- OPEN CUT NOTES:
 - A UTILITY CUT PERMIT IS REQUIRED FOR EACH OPEN CUT OF A CITY STREET. CONTACT 910-341-5888 FOR MORE DETAILS. IN CERTAIN CASES AN ENTIRE RESURFACING OF THE AREA BEING OPEN CUT MAY BE REQUIRED.
 - CONTRACTOR TO COORDINATE WITH CITY OF WILMINGTON FOR ACCEPTABLE HOURS OF CONSTRUCTION AND TRAFFIC CONTROL DURING INSTALLATION OF UTILITIES IN CITY ROADS.
 - SUITABLE COMPACTION AND APPROVED STONE & BASE COURSES TO BE INSTALLED IN PLACE OF OPEN CUT.
 - OPEN CUT TO BE SAW CUT.
- ALL PAVEMENT MARKINGS IN PUBLIC RIGHTS OF WAY AND FOR DRIVEWAYS ARE TO BE THERMOPLASTIC AND MEET CITY AND/OR MUTCD STANDARDS.
- IT SHALL BE THE RESPONSIBILITY OF THE SUBDIVIDER TO ERECT OFFICIAL STREET NAME SIGNS AT ALL INTERSECTIONS ASSOCIATED WITH THE SUBDIVISION IN ACCORDANCE WITH THE TECHNICAL STANDARDS AND SPECIFICATIONS MANUAL. THE SUBDIVIDER MAY ACQUIRE AND ERECT OFFICIAL STREET NAME SIGNS OR MAY CHOOSE TO CONTRACT WITH THE CITY TO INSTALL THE STREET SIGNS AND THE SUBDIVIDER SHALL PAY THE COST OF SUCH INSTALLATION. CONTACT TRAFFIC ENGINEERING AT 341-7888 TO DISCUSS INSTALLATION OF TRAFFIC AND STREET NAME SIGNS. PROPOSED STREET NAMES MUST BE APPROVED PRIOR TO INSTALLATION OF STREET NAME SIGNS.
- CALL TRAFFIC ENGINEERING AT 341-7888 FORTY-EIGHT HOURS PRIOR TO ANY EXCAVATION IN THE RIGHT OF WAY.
- TACTILE WARNING MATS ARE TO BE INSTALLED ON ALL WHEELCHAIR RAMPS.
- ANY BROKEN OR MISSING SIDEWALK PANELS, DRIVEWAY PANELS AND CURBS WILL BE REPLACED.
- ALL TRAFFIC CONTROL SIGNS AND MARKINGS OFF THE RIGHT OF WAY ARE TO BE MAINTAINED BY THE PROPERTY OWNER IN ACCORDANCE WITH MUTCD STANDARDS.
- ALL PARKING STALL MARKINGS AND LANE ARROWS WITHIN THE PARKING AREA SHALL BE WHITE.
- CONTACT TRAFFIC ENGINEERING AT 341-7888 TO DISCUSS STREET LIGHTING OPTIONS.
- ALL PROPOSED VEGETATION WITHIN SIGHT TRIANGLES SHALL NOT INTERFERE WITH CLEAR VISUAL SIGHT LINES FROM 30 INCHES - 10 FT.
- TRAFFIC ENGINEERING MUST APPROVE PAVEMENT MARKING LAYOUT PRIOR TO ACTUAL STRIPING.
- A SUBDIVISION STREET DISCLOSURE STATEMENT SHALL BE PROVIDED TO BUYERS AT THE POINT OF SALE OF LOTS.
- A SIGN SHALL BE LOCATED AT THE SOUTHERN END OF AURIANA WAY INDICATING THAT A FUTURE CONNECTION WILL BE OPENED WHEN THE PROPERTY TO THE SOUTH DEVELOPS.

ENVIRONMENTAL NOTES:

- NO LAND DISTURBANCE IS PERMITTED OUTSIDE THE DESIGNATED LIMITS OF DISTURBANCE FOR SITE IMPROVEMENTS OTHER THAN WHAT IS NECESSARY TO THE INTO EXISTING CONTOURS OR MEET LANDSCAPING REQUIREMENTS.

DEVELOPMENT NOTES:

- ALL SIGNS AND PAVEMENT MARKINGS IN AREAS OPEN TO PUBLIC TRAFFIC ARE TO MEET MUTCD STANDARDS.
- THE CONTRACTOR IS RESPONSIBLE FOR THE LOCATION AND PROTECTION OF EXISTING UTILITIES DURING CONSTRUCTION. CALL U-LOC AT 1-800-632-6949. CONTRACTOR IS RESPONSIBLE FOR THE REPAIR AND REPLACEMENT OF ANY UTILITIES, CURB AND GUTTER, SIDEWALK PANELS, PAVEMENT, ETC. THAT MAY BE DAMAGED DURING CONSTRUCTION. DAMAGED ITEMS SHALL BE REPAIRED TO AT LEAST THE QUALITY OR WORKMANSHIP FOUND IN THE ORIGINAL ITEM.
- SOLID WASTE DISPOSAL WILL BE HAND TOTES.
- ALL DEVELOPMENT SHALL BE IN ACCORDANCE WITH THE CITY OF WILMINGTON ZONING ORDINANCE & SUBDIVISION REGULATIONS.
- APPROVAL OF SITE PLAN DOES NOT CONSTITUTE APPROVAL OF PROPOSED SIGNING FOR THIS SITE. A SEPARATE SIGN PERMIT MUST BE OBTAINED.
- APPLICABLE STREET FRONTAGES SHALL HAVE NATURAL VEGETATIVE SCREENING MEETING CITY REQUIREMENTS.
- THE DEVELOPMENT SHALL COMPLY WITH ALL CITY TECHNICAL STANDARDS AND DEVELOPMENT REGULATIONS.
- PRIMARY BUILDING ENTRANCES SHALL BE CLEARLY DEFINED AND SHALL BE RECESSED AT LEAST FIVE FEET OR FRAMED BY AN ARCHITECTURAL ELEMENT. PRIMARY ENTRANCES SHOULD BE CLEARLY DISTINCTIVE FROM OTHER ENTRANCES. SECONDARY OUTSIDE BUILDING ENTRANCES TO UPPER FLOORS ON THE PRIMARY FACADE SHALL ALIGN WITH THE OUTER MOST WINDOW ON THE FRONT FACADE.

WATER & SEWER USAGE NOTES:

CURRENT WATER USAGE	0 GPD	PROPOSED WATER USAGE	14,400 GPD
CURRENT SEWER USAGE	0 GPD	PROPOSED SEWER USAGE	14,400 GPD

WATER - 140 X 360 GPD = 14,400 GPD
 SEWER - 140 X 360 GPD = 14,400 GPD

FIRE & LIFE SAFETY NOTES:

- LANDSCAPING OR PARKING CANNOT BLOCK OR IMPED FIRE HYDRANTS OR FDC'S. A 3FT CLEAR SPACE SHALL BE MAINTAINED AROUND THE CIRCUMFERENCE OF THE HYDRANT.
- CONTRACTOR SHALL MAINTAIN AN ALL WEATHER ACCESS FOR EMERGENCY VEHICLES AT ALL TIMES DURING CONSTRUCTION.
- PRIVATE UNDERGROUND FIRE LINES REQUIRE A SEPARATE FIRE LINE PERMIT FROM COW FIRE AND LIFE SAFETY DIVISION. 910-343-0888.
- FIRE HYDRANTS TO BE INSTALLED PER CITY OF WILMINGTON ORDINANCE AND CPDIA STANDARDS.

UTILITY NOTES:

- PROJECT SHALL COMPLY WITH THE CITY OF WILMINGTON AND CPDIA CROSS CONNECTION CONTROL REQUIREMENTS. WATER METER(S) CANNOT BE SET AND ACTIVATED ON NEW MAINS UNTIL ALL REQUIREMENTS ARE MET. CALL 343-3910 FOR INFORMATION.
- IF THE CONTRACTOR IS PROVIDING WATER SERVICE HE/SHE SHALL APPLY IN ADVANCE FOR THIS SERVICE AND MUST PROVIDE A REDUCED PRESSURE ZONE (RPZ) BACKFLOW PREVENTION DEVICE ON THE DEVELOPER'S SIDE OF THE WATER METER BOX.
- ALL COMMERCIAL WATER SERVICES AND ANY IRRIGATION SYSTEMS SUPPLIED BY CPDIA WATER SHALL HAVE A BACKFLOW PREVENTION DEVICE ACCEPTABLE TO THE CPDIA AND APPROVED BY USPOCOOR OR ASSE. CALL 799-5064 FOR INFORMATION.
- WHEN PVC WATER MAINS AND/OR POLYETHYLENE SERVICES ARE PROPOSED, THE PIPES ARE TO BE MARKED WITH NO. 10 INSULATED COPPER WIRE INSTALLED THE ENTIRE LENGTH AND STRAPPED TO THE PIPES. THE COPPER WIRE IS TO BE INSTALLED TO GARE WIRE AND SECURED TO ALL VALVES AND FITTINGS. THE WIRE IS TO BE ACCESSIBLE AT ALL FIRE HYDRANTS AND WATER METER BOXES TO AID IN FUTURE LOCATION OF FACILITIES.
- 36" MINIMUM COVER OVER ALL WATER MAINS.
- ANY SEPARATE CONNECTION FOR IRRIGATION SHALL COMPLY WITH CITY AND CPDIA CROSS-CONNECTION REQUIREMENTS WITH APPROVED BACKFLOW PREVENTION DEVICES.
- AT LOCATIONS WHERE WATER MAIN CROSSES UNDER SANITARY SEWER, DUCTILE IRON PIPE SHALL BE USED ALONG WITH PROVIDING 24" MINIMUM OF VERTICAL SEPARATION.
- WATER SERVICES CAN NOT BE ACTIVATED ON NEW WATER MAINS UNTIL ENGINEER'S CERTIFICATION AND APPLICANT'S CERTIFICATION HAVE BEEN PROVIDED TO NCDNR AND "FINAL APPROVAL" ISSUED.
- UNDERGROUND UTILITIES- ALL NEW UTILITIES SHALL BE INSTALLED UNDERGROUND, EXCEPT WHERE SUCH PLACEMENT IS PROHIBITED OR DEEMED IMPRACTICAL BY THE UNDERGROUND UTILITIES FACILITIES FOR STREET LIGHTING ALONG ALL PUBLIC STREETS ADJACENT TO THE SUBJECT SITE SHALL BE INSTALLED BY THE DEVELOPER.

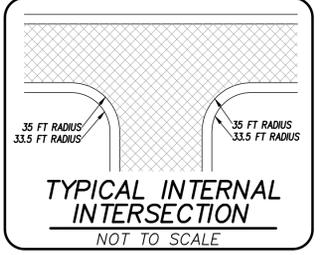
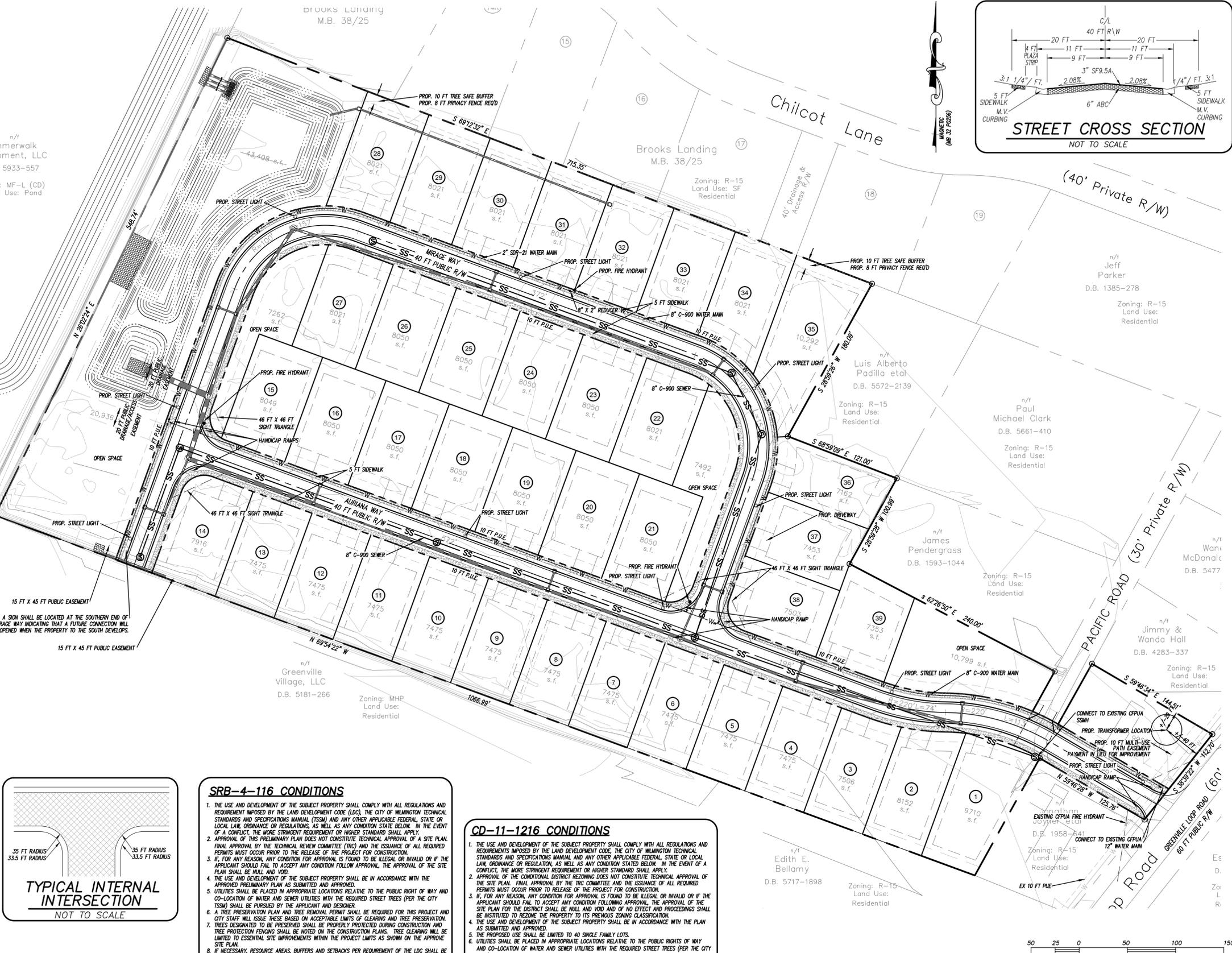

SRB-4-116 CONDITIONS

- THE USE AND DEVELOPMENT OF THE SUBJECT PROPERTY SHALL COMPLY WITH ALL REGULATIONS AND REQUIREMENTS IMPOSED BY THE LAND DEVELOPMENT CODE (LDC), THE CITY OF WILMINGTON TECHNICAL STANDARDS AND SPECIFICATIONS MANUAL (TSSM) AND ANY OTHER APPLICABLE FEDERAL, STATE OR LOCAL LAW, ORDINANCE OR REGULATIONS, AS WELL AS ANY CONDITION STATED BELOW. IN THE EVENT OF A CONFLICT, THE MORE STRINGENT REQUIREMENT OR HIGHER STANDARD SHALL APPLY.
- APPROVAL OF THIS PRELIMINARY PLAN DOES NOT CONSTITUTE TECHNICAL APPROVAL OF A SITE PLAN. FINAL APPROVAL BY THE TECHNICAL REVIEW COMMITTEE (TRC) AND THE ISSUANCE OF ALL REQUIRED PERMITS MUST OCCUR PRIOR TO THE RELEASE OF THE PROJECT FOR CONSTRUCTION.
- IF, FOR ANY REASON, ANY CONDITION FOR APPROVAL IS FOUND TO BE ILLEGAL OR INVALID OR IF THE APPLICANT SHOULD FAIL TO ACCEPT ANY CONDITION FOLLOWING APPROVAL, THE APPROVAL OF THE SITE PLAN SHALL BE NULL AND VOID.
- THE USE AND DEVELOPMENT OF THE SUBJECT PROPERTY SHALL BE IN ACCORDANCE WITH THE APPROVED PRELIMINARY PLAN AS SUBMITTED AND APPROVED.
- UTILITIES SHALL BE PLACED IN APPROPRIATE LOCATIONS RELATIVE TO THE PUBLIC RIGHT OF WAY AND CO-LOCATION OF WATER AND SEWER UTILITIES WITH THE REQUIRED STREET TREES (PER THE CITY TSSM) SHALL BE PURSUED BY THE APPLICANT AND DESIGNER.
- A TREE PRESERVATION PLAN AND TREE REMOVAL PERMIT SHALL BE REQUIRED FOR THIS PROJECT AND CITY STAFF WILL ISSUE THESE BASED ON ACCEPTABLE LIMITS OF CLEARING AND TREE PRESERVATION.
- TREES DESIGNATED TO BE PRESERVED SHALL BE PROPERLY PROTECTED DURING CONSTRUCTION AND TREE PROTECTION FENCING SHALL BE NOTED ON THE CONSTRUCTION PLANS. TREE CLEARING WILL BE LIMITED TO ESSENTIAL SITE IMPROVEMENTS WITHIN THE PROJECT LIMITS AS SHOWN ON THE APPROVE SITE PLAN.
- IF NECESSARY, RESOURCE AREAS, BUFFERS AND SETBACKS PER REQUIREMENT OF THE LDC SHALL BE SHOWN AND LABELED ON THE PRELIMINARY PLAN.
- ALL EXISTING AND PROPOSED PUBLIC AND NON-MUNICIPAL EASEMENTS SHALL BE ADDED AS NECESSARY TO THE PRELIMINARY PLAN.
- AN ACCEPTABLE PRELIMINARY PLAN WHICH ADEQUATELY ADDRESSES ALL TRC/SRB COMMENTS SHALL BE SUBMITTED FOR SIGNATURE WITHIN THIRTY (30) CALENDAR DAYS OF SRB APPROVAL.
- THE APPLICANT SHALL OBTAIN APPROVAL OF THE STREET NAMES FROM THE CITY ADDRESSING COORDINATOR AND PLACE THE APPROVED NAME ON THE PRELIMINARY PLAN. THIS IS REQUIRED PRIOR TO PLAT RECORDATION AND/OR SITE PLAN SUBMISSION.
- A TREE PRESERVATION PLAN AND TREE REMOVAL PERMIT SHALL BE REQUIRED FOR THIS PROJECT AND CITY STAFF WILL ISSUE THESE BASED ON ACCEPTABLE LIMITS OF CLEARING AND TREE PRESERVATION.
- THE PROPOSED PUBLIC STREET SHALL BE BUILT TO RESIDENTIAL STREET STANDARDS.
- ALL CITY, STATE, FEDERAL, RESUBDIVISION AND LOCAL REGULATIONS SHALL BE MET.
- A SIGN SHALL BE POSED AT THE TERMINUS OF THE SUB STREET GIVING PUBLIC NOTICE OF A FUTURE ROAD CONNECTION.
- ADEQUATE SIGHT DISTANCE MUST BE ESTABLISHED AND MAINTAINED FOR VEHICULAR MOVEMENTS ENTERING AND LEAVING THE SUBDIVISION.
- AN 8-10 FT WIDE MULTI-USE PATH SHALL BE PROVIDED ALONG THE GREENVILLE LOOP ROAD FRONTAGE.
- THE APPLICANT SHALL ENSURE ADEQUATE EMERGENCY ACCESS IS PROVIDED AND MAINTAINED TO AND FROM THE EXISTING 30 FT PRIVATE RIGHT OF WAY THAT CONNECTS TO THE PROPOSED PUBLIC STREET.

CD-11-1216 CONDITIONS

- THE USE AND DEVELOPMENT OF THE SUBJECT PROPERTY SHALL COMPLY WITH ALL REGULATIONS AND REQUIREMENTS IMPOSED BY THE LAND DEVELOPMENT CODE, THE CITY OF WILMINGTON TECHNICAL STANDARDS AND SPECIFICATIONS MANUAL, AND ANY OTHER APPLICABLE FEDERAL, STATE OR LOCAL LAW, ORDINANCE OR REGULATION, AS WELL AS ANY CONDITION STATED BELOW. IN THE EVENT OF A CONFLICT, THE MORE STRINGENT REQUIREMENT OR HIGHER STANDARD SHALL APPLY.
- APPROVAL OF THE CONDITIONAL DISTRICT ZONING DOES NOT CONSTITUTE TECHNICAL APPROVAL OF THE SITE PLAN. FINAL APPROVAL BY THE TRC COMMITTEE AND THE ISSUANCE OF ALL REQUIRED PERMITS MUST OCCUR PRIOR TO RELEASE OF THE PROJECT FOR CONSTRUCTION.
- IF, FOR ANY REASON, ANY CONDITION FOR APPROVAL IS FOUND TO BE ILLEGAL OR INVALID OR IF THE APPLICANT SHOULD FAIL TO ACCEPT ANY CONDITION FOLLOWING APPROVAL, THE APPROVAL OF THE SITE PLAN FOR THE DISTRICT SHALL BE NULL AND VOID OF NO EFFECT AND PROCEEDINGS SHALL BE INSTITUTED TO REZONE THE PROPERTY TO ITS PREVIOUS ZONING CLASSIFICATION.
- THE USE AND DEVELOPMENT OF THE SUBJECT PROPERTY SHALL BE IN ACCORDANCE WITH THE PLAN AS SUBMITTED AND APPROVED.
- THE PROPOSED USE SHALL BE LIMITED TO 40 SINGLE FAMILY LOTS.
- UTILITIES SHALL BE PLACED IN APPROPRIATE LOCATIONS RELATIVE TO THE PUBLIC RIGHTS OF WAY AND CO-LOCATION OF WATER AND SEWER UTILITIES WITH THE REQUIRED STREET TREES (PER THE CITY TSSM) SHALL BE PURSUED BY THE APPLICANT AND DESIGNER.
- A TREE PRESERVATION PLAN AND TREE REMOVAL PERMIT SHALL BE REQUIRED FOR THIS PROJECT AND CITY STAFF SHALL ISSUE THESE BASED ON ACCEPTABLE LIMITS OF CLEARING AND TREE PRESERVATION.
- TREES DESIGNATED TO BE PRESERVED SHALL BE PROPERLY PROTECTED DURING CONSTRUCTION AND TREE PROTECTION FENCING SHALL BE NOTED ON THE CONSTRUCTION PLANS. TREE CLEARING WILL BE LIMITED TO ESSENTIAL SITE IMPROVEMENTS WITHIN THE PROJECT LIMITS AS SHOWN ON THE APPROVED SITE PLAN.
- ALL EXISTING PROTECTED TREES NOT LOCATED WITHIN BUILDING FOOTPRINT OR IMPACTED BY ESSENTIAL SITE IMPROVEMENT SHALL BE PRESERVED OR MITIGATED.
- A TREE PRESERVATION PLAN AND TREE REMOVAL PERMIT SHALL BE REQUIRED FOR THIS PROJECT AND CITY STAFF SHALL ISSUE THESE BASED ON ACCEPTABLE LIMITS OF CLEARING AND TREE PRESERVATION.
- TREES DESIGNATED TO BE PRESERVED SHALL BE PROPERLY PROTECTED DURING CONSTRUCTION AND TREE PROTECTION FENCING SHALL BE NOTED ON THE CONSTRUCTION PLANS. TREE CLEARING WILL BE LIMITED TO ESSENTIAL SITE IMPROVEMENTS WITHIN THE PROJECT LIMITS AS SHOWN ON THE APPROVED SITE PLAN.
- SIDEWALKS AND STREET TREES SHALL BE INSTALLED BY THE DEVELOPER ALONG BOTH SIDES OF THE PROPOSED PRIVATE STREETS.
- PROPOSED PUBLIC STREETS SHALL BE BUILT TO RESIDENTIAL STREET STANDARDS.
- ADEQUATE SIGHT DISTANCE MUST BE ESTABLISHED AND MAINTAINED FOR VEHICULAR MOVEMENTS ENTERING AND LEAVING THE SUBDIVISION.
- AN 8-10 FT WIDE MULTI-USE PATH SHALL BE PROVIDED ALONG THE GREENVILLE LOOP ROAD FRONTAGE.
- ALL CITY, STATE AND FEDERAL REGULATIONS SHALL BE MET.
- AN 8 FOOT TALL PRIVACY FENCE AND A 10 FOOT WIDE TREE SAVE AREA (BUFFER) SHALL BE PROVIDED VIA DEED RESTRICTION ALONG THE NORTHERN BOUNDARY ADJACENT TO LOTS 28 THRU 36.

GENERAL NOTES:

- NEW HANOVER COUNTY PARCEL NUMBERS: PID = 6212-001-008 & 6212-001-002
- TOTAL PROJECT AREA: 462,028 SF (11.08 AC.)
- EXISTING ZONING DISTRICT: R7 CD
- LAND CLASSIFICATION: WATER RESOURCE PROTECTION
- THIS SITE IS LOCATED WITHIN ZONE "X" ACCORDING TO FEMA FIRM COMMUNITY PANEL NUMBER 3720J15600L, EFFECTIVE DATE 4/3/06
- DATE ADDRESS: 6561 GREENVILLE LOOP ROAD
- EXISTING IMPERVIOUS ONSITE = 0 SF
- ASBUILT BOUNDARY AND TOPOGRAPHIC SURVEY PERFORMED AND PROVIDED TO CSD ENGINEERING BY GEOINNOVATION, PC
- STORMWATER DRAINS TO BRADLEY CREEK, SC 18-87-24-(4)2
- LAND OWNER - ARYA HOLDINGS, LLC
 PO BOX 3122
 WILMINGTON, NC 28406

BUILDING AND SITE DATA:

TOTAL LOTS PROPOSED	40 LOTS	IMPERVIOUS SURFACES -	STREETS (CURB & PAVT) -	49,854 SF
(PROPOSED RESIDENCES ARE SINGLE-FAMILY STRUCTURES W/ MAX. 3 BEDROOMS)		LOTS -	LOT -	120,000 SF
AREA DENSITY = 1.6 UNITS/AC.		SIDEWALK -		21,378 SF
AREA OF LOTS PROPOSED - 6.68 AC.		TOTAL -		191,832 SF (38.7%)
AREA OF R/W DEDICATION - 2.04 AC.				
COMMON & RECREATION AREAS - 2.38 AC.				
AVERAGE LOT SIZE = 7254 SF				
TOTAL PROPOSED ROAD LENGTH - 2247 LF				
RECREATION SPACE -				
40 LOTS @ 0.03 AC/LOT = 1.20 AC ± RECD.				
AREA PROVID. - 1.43 AC ± **				
SETBACKS - 30' FRONT				
8.5' SIDE				
15' REAR				

Approved Construction Plan

Name _____ Date _____

Planning _____

Traffic _____

Fire _____

CITY OF WILMINGTON
 NORTH CAROLINA
 Public Services • Engineering Division
 APPROVED STORMWATER MANAGEMENT PLAN

Date: _____ Permit # _____

Signed: _____

For each open utility cut of City streets, a \$325 permit shall be required from the City prior to occupancy and/or project acceptance.

CHECKED BY: HSR

PROJECT NO.: 17-0398

PRELIMINARY PLAN for
PACIFIC PLACE
 LOCATED IN CITY OF WILMINGTON
 NEW HANOVER COUNTY, NORTH CAROLINA
 OWNER: ARYA HOLDINGS, LLC
 1805 5122
 WILMINGTON, NC 28406

PRELIMINARY PLAN for
PACIFIC PLACE
 LOCATED IN CITY OF WILMINGTON
 NEW HANOVER COUNTY, NORTH CAROLINA
 OWNER: ARYA HOLDINGS, LLC
 1805 5122
 WILMINGTON, NC 28406



REV.	DATE	BY	REMARKS
7	5/2/19	ARB	REVISED DRAINAGE EASEMENT LOTS 1-5
6	11/13/18	ARB	ADDED TRANSFORMER LOCATION
5	7/26/18	ARB	REVISED LOT LAYOUT AND NUMBERING
4	1/15/18	ARB	FLATTED FOR CITY SIGNATURES
3	12/17/17	ARB	ADDED STREET LIGHTS
2	9/25/17	ARB	REVISED ROAD NAMES
1	9/26/17	ARB	REVISED PER TRC COMMENTS

DATE: 7-12-17

HORIZ. SCALE: 1" = 50'

VERT. SCALE: N/A

DRAWN BY: RLW

CHECKED BY: HSR

PROJECT NO.: 17-0398

Sheet No. **5** of **15**

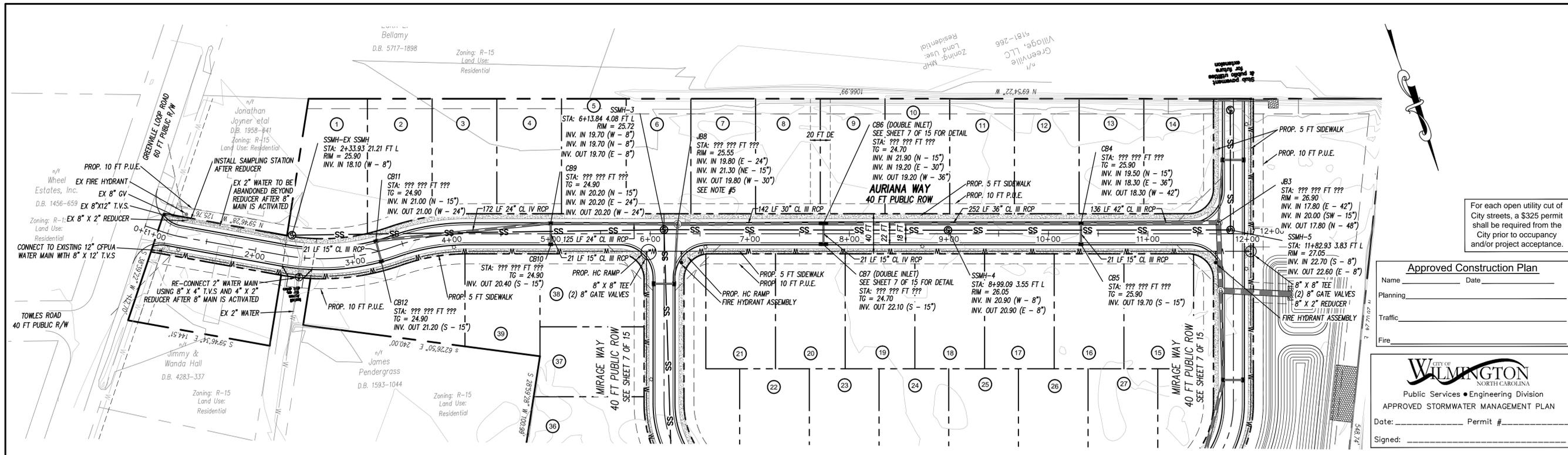

For each open utility cut of City streets, a \$325 permit shall be required from the City prior to occupancy and/or project acceptance.

Approved Construction Plan

Name: _____ Date: _____

Planning: _____

Traffic: _____

Fire: _____

WILMINGTON
Public Services Engineering Division
APPROVED STORMWATER MANAGEMENT PLAN

Date: _____ Permit # _____

Signed: _____

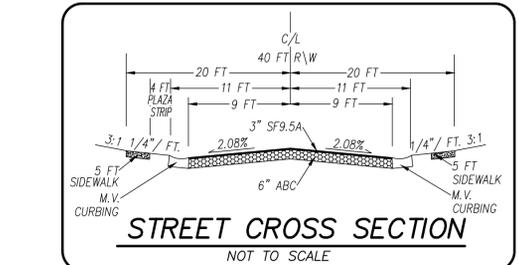
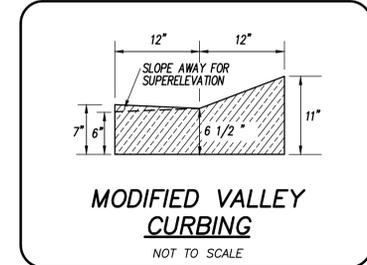
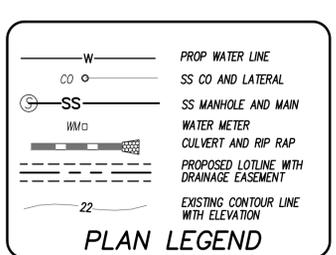
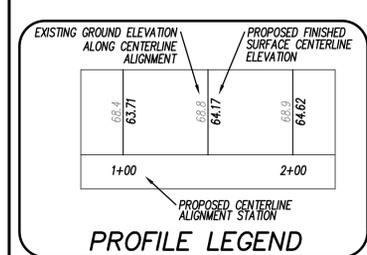
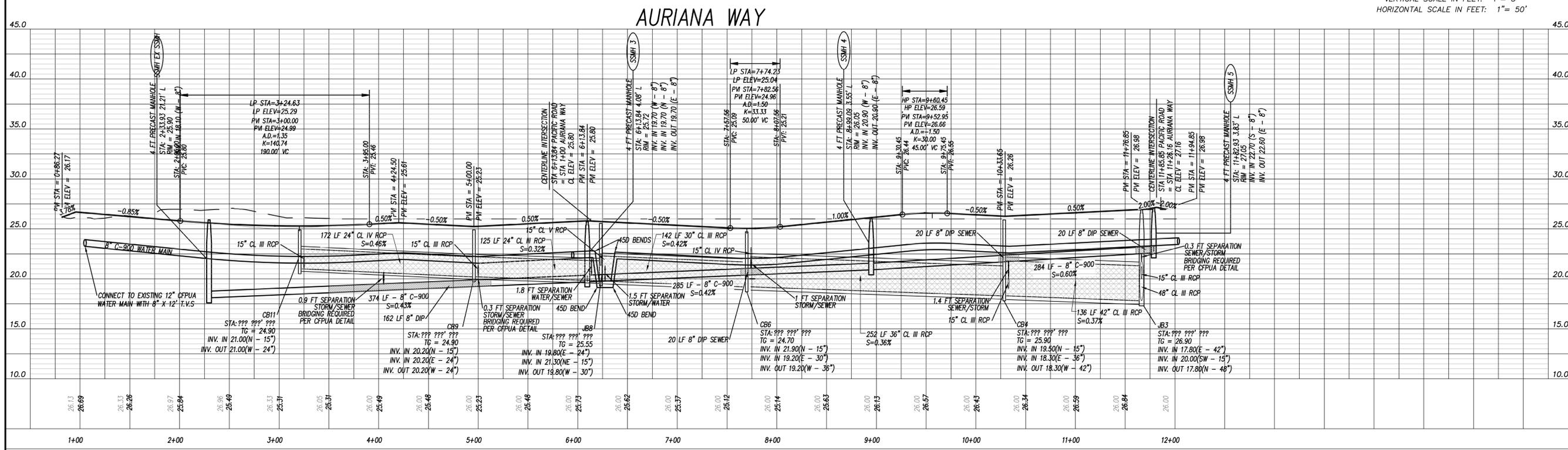
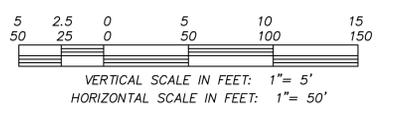

UTILITY NOTE:

1. WATER SERVICES CANNOT BE LOCATED MORE THAN FIVE FEET INTO PUBLIC UTILITY EASEMENT.

STORMWATER DRAINAGE STRUCTURE NOTES

1. CONTRACTOR AND PRECASTER TO DETERMINE STORM STRUCTURE SIZES.
2. FRAME AND GRATES TO BE NCDOT STD. 840.54
3. STORM STRUCTURES TO BE NCDOT STD. 840.46
4. PRECAST STORM STRUCTURES TO MEET HS-20-44 LOADING.
5. CONTRACTOR TO INSTALL ACCESS COVERS SO THEY ARE NOT LOCATED WITHIN THE CURB AND GUTTER.

CEPWA STANDARD NOTES:

1. SEWER GUARDS REQUIRED AT ALL MANHOLES. STAINLESS STEEL SEWER GUARDS REQUIRED AT MANHOLES LOCATED IN TRAFFIC AREAS.
2. WATER AND SEWER SERVICES SHALL BE PERPENDICULAR TO MAIN AND TERMINATE AT R/W LINE. SEWER SERVICES IN CUL-DE-SACS ARE REQUIRED TO BE PERPENDICULAR, OR MUST ORIGINATE IN END OF LINE MANHOLE AND TERMINATE AT RIGHT-OF-WAY LINE.
3. ALL SERVICES TYING INTO DUCTILE IRON MAINS SHALL BE CONSTRUCTED OF CLASS 50 DIP, WITH PROTECTO-401 CERAMIC EPOXY LINING.
4. MINIMUM 10' UTILITIES EASEMENT PROVIDED ALONG THE FRONTAGE OF ALL LOTS AND AS SHOWN FOR NEW DEVELOPMENTS.
5. NO FLEXIBLE COUPLINGS SHALL BE USED.
6. ALL STAINLESS STEEL FITTINGS SHALL BE 316.
7. CLEANOUTS SHALL BE LOCATED A MINIMUM OF 12 FEET FROM ALL PROPERTY CORNERS. WATER METER BOXES ARE TO BE A MINIMUM OF 5 FEET FROM THE PROPERTY CORNER.

CSD ENGINEERING

LICENSE # C-2710
ENGINEERING
LAND PLANNING
COMMERCIAL / RESIDENTIAL

P.O. BOX 4041
WILMINGTON, NC 28406
(910) 791-4441

STATION 0+82 THROUGH 12+00.06
AURIANA WAY

PLAN AND PROFILES FOR
PACIFIC PLACE
LOCATED IN CITY OF WILMINGTON
NEW HANOVER COUNTY, NORTH CAROLINA

OWNER: ARYA HOLDINGS, LLC
1005 SHELBY
WILMINGTON, NC 28406



REV.	DATE	BY	REMARKS
6	5/2/19	MRB	REVISED DRAINAGE EASEMENT BEHIND LOTS 1-5
5	7/26/18	MRB	REVISED LOT LAYOUT AND NUMBERING
4	1/15/18	MRB	FLATTED FOR CITY SIGNATURES
3	12/11/17	RLW	ADDED COW STAMPS
2	10/9/17	RLW	CHANGED C86 & 7 TO DOUBLE INLETS
1	9/26/17	MRB	REVISED PER CEPWA COMMENTS, REISED ROAD NAMES

DATE: 7-12-17
HORZ. SCALE: 1" = 50'
VERT. SCALE: 1" = 5'
DRAWN BY: RLW
CHECKED BY: HSR
PROJECT NO.: 17-0398
Sheet No. **6** of **15**

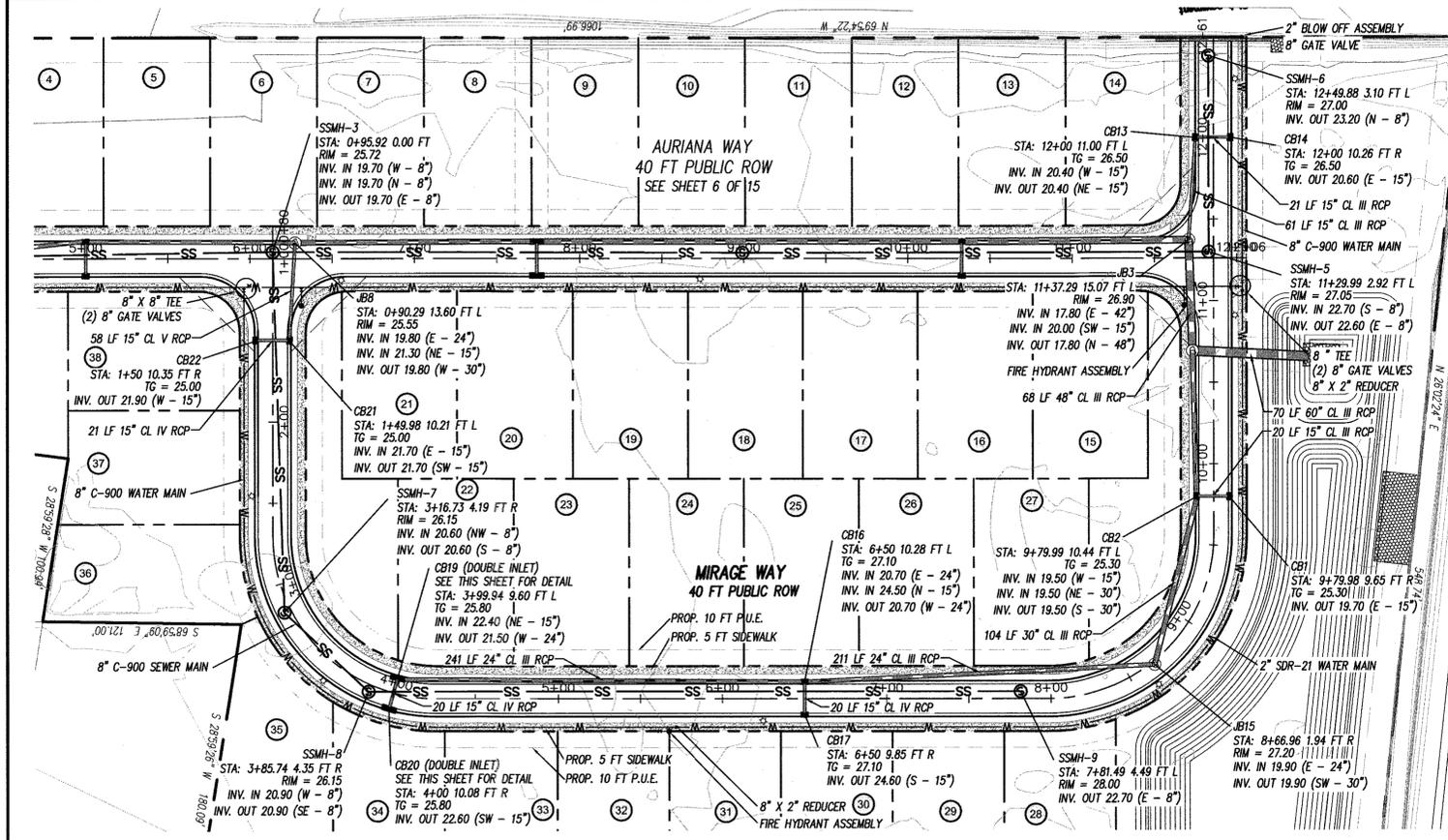

Approved Construction Plan

Name: _____ Date: _____

Planning: _____

Traffic: _____

Fire: _____

WILMINGTON
NORTH CAROLINA

Public Services • Engineering Division

APPROVED STORMWATER MANAGEMENT PLAN

Date: _____ Permit # _____

Signed: _____

BOLT BOXES TOGETHER AND CUT OUT OPENING BETWEEN THE TWO BOXES OR PRECAST.

SECTION VIEW

A - TO BE SIZED PER INLET PIPE COMING INTO BOX BOXES TO MEET NCDOT STD 840.02 REQUIREMENTS. TO BE USED AT INLETS CB6,CB7,CB15,CB20

DOUBLE INLET

NOT TO SCALE

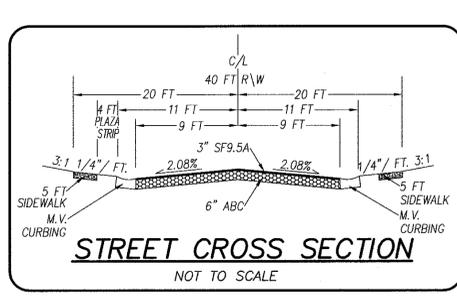
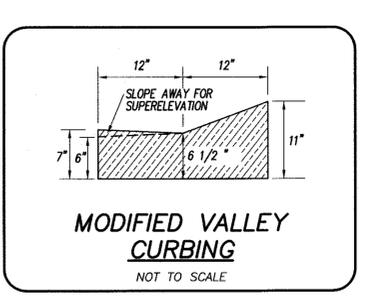
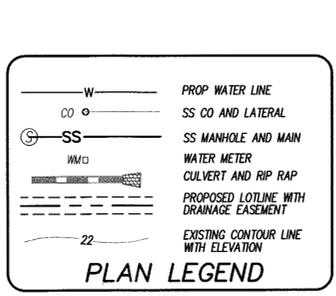
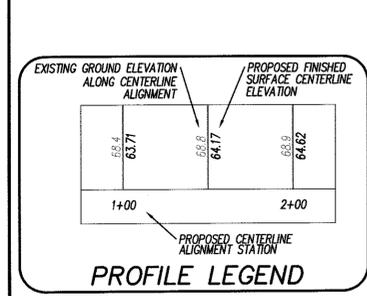
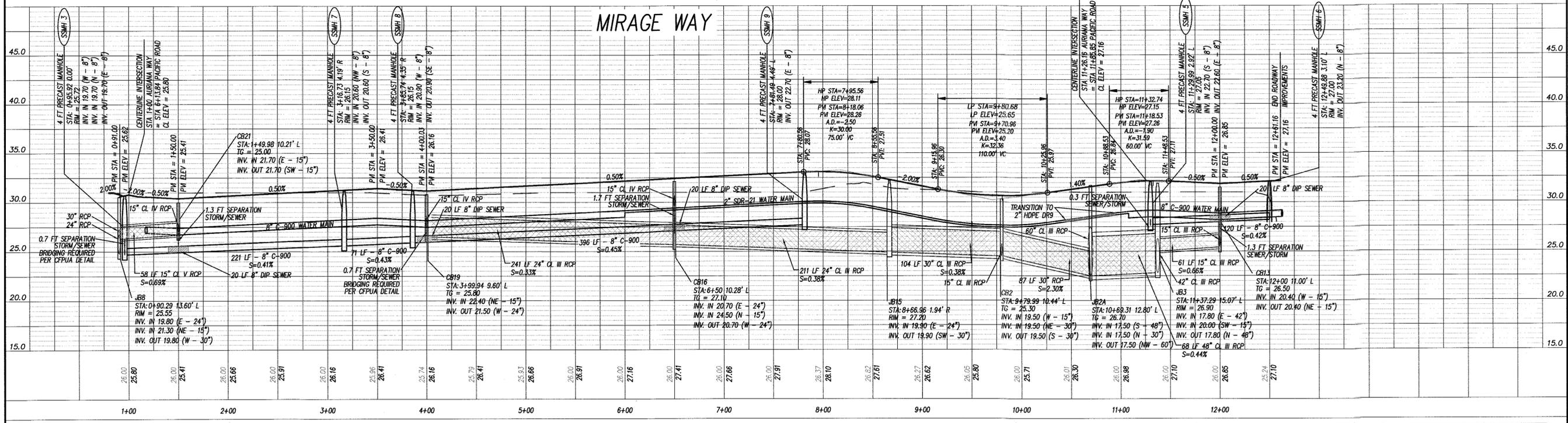
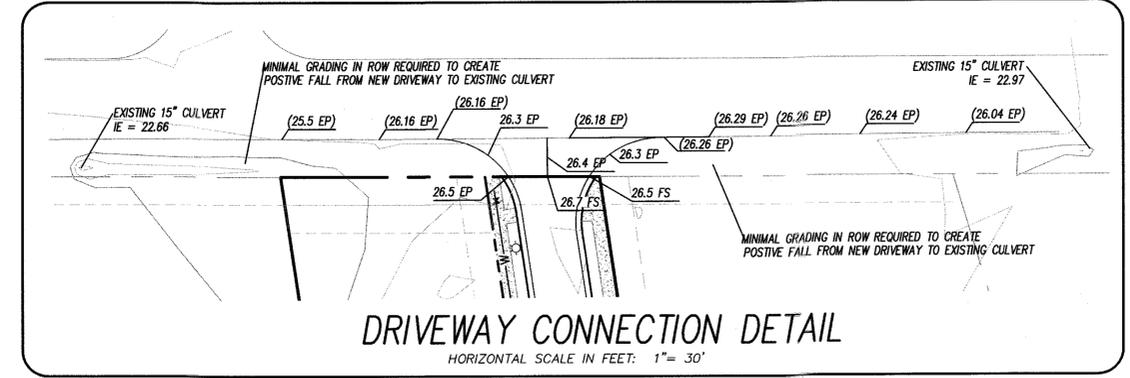

UTILITY NOTE:

1. WATER SERVICES CANNOT BE LOCATED MORE THAN FIVE FEET INTO PUBLIC UTILITY EASEMENT.

STORMWATER DRAINAGE STRUCTURE NOTES

1. CONTRACTOR AND PRECASTER TO DETERMINE STORM STRUCTURE SIZES.
2. FRAME AND GRATES TO BE NCDOT 840.03
3. RING AND COVERS TO BE NCDOT STD. 840.54
4. STORM STRUCTURES TO BE NCDOT STD. 840.46
5. PRECAST STORM STRUCTURES TO MEET HS-20-44 LOADING.
6. CONTRACTOR TO INSTALL ACCESS COVERS SO THEY ARE NOT LOCATED WITHIN THE CURB AND GUTTER

CEPWA STANDARD NOTES:

1. SEWER GUARDS REQUIRED AT ALL MANHOLES. STAINLESS STEEL SEWER GUARDS REQUIRED AT MANHOLES LOCATED IN TRAFFIC AREAS.
2. WATER AND SEWER SERVICES SHALL BE PERPENDICULAR TO MAIN AND TERMINATE AT R/W LINE. SEWER SERVICES IN CUL-DE-SACS ARE REQUIRED TO BE PERPENDICULAR, OR MUST ORIGINATE IN END OF LINE MANHOLE AND TERMINATE AT RIGHT-OF-WAY LINE.
3. ALL SERVICES TYPING INTO DUCTILE IRON MAINS SHALL BE CONSTRUCTED OF CLASS 50, DIP, WITH PROTECTO 401 CERAMIC EPOXY LINING.
4. MINIMUM 10' UTILITIES EASEMENT PROVIDED ALONG THE FRONTAGE OF ALL LOTS AND AS SHOWN FOR NEW DEVELOPMENTS.
5. NO FLEXIBLE COUPLINGS SHALL BE USED.
6. ALL STAINLESS STEEL FITTINGS SHALL BE 316.
7. CLEANOUTS SHALL BE LOCATED A MINIMUM OF 12 FEET FROM ALL PROPERTY CORNERS. WATER METER BOXES ARE TO BE A MINIMUM OF 5 FEET FROM THE PROPERTY CORNER.

CSD ENGINEERING

LICENSE # C-2710

ENGINEERING
LAND PLANNING
COMMERCIAL / RESIDENTIAL

P.O. BOX 4041
WILMINGTON, NC 28406
(910) 791-4441

PLAN AND PROFILES FOR

PACIFIC PLACE

LOCATED IN CITY OF WILMINGTON
NEW HANOVER COUNTY, NORTH CAROLINA

OWNER: ARYA HOLDINGS, LLC
P.O. BOX 3122
WILMINGTON, NC 28406

STATION 0+82 THROUGH 12+00.06
MIRAGE WAY

PROFESSIONAL ENGINEER

STATE OF NORTH CAROLINA

SEAL 025483

7/25/18

REV. NO.	DATE	BY	REMARKS
5	7/26/18	MRB	REVISED LOT LAYOUT/NUMBERING & MOVED HOPE SECTION OF WATER MAIN
4	1/15/18	MRB	PICTURED FOR CITY STAMPS, REVISIONS, ENTRANCE DETAIL
3	12/17/17	RLW	ADDED AREA CHANGED CBIP # 20 TO DOUBLE INLETS
2	10/09/17	BLM	REVISED PER OPWA COMMENTS, REVISED ROAD NAMES
1	9/29/17	MRB	

DATE: 7-12-17

HORIZ. SCALE: 1" = 50'

VERT. SCALE: 1" = 5'

DRAWN BY: RLW

CHECKED BY: HSR

PROJECT NO.: 17-0398

Sheet No. **7** of **15**

LANDSCAPE PLAN for
PACIFIC PLACE

LANDSCAPE PLAN for
PACIFIC PLACE
LOCATED IN CITY OF WILMINGTON
NEW HANOVER COUNTY, NORTH CAROLINA
OWNER: ARYA HOLDINGS, LLC
PO BOX 3122
WILMINGTON, NC 28406

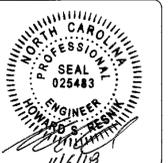

REV. NO.	DATE	BY	REMARKS
7	9-08-17	RLW	REVISED PER LOT LINE SHIFTS
6	11-15-16	MRB	ADDED FIRE CITY SIGNATURES
5	11-15-16	RLW	REVISED STREET TREES
4	12-11-17	RLW	REVISED STREET TREES
3	11-27-17	RLW	ADDED XERISCAPING NOTES
2	11-29-17	RLW	ADDED ADDITIONAL STREET TREES
1	9-25-17	MRB	REVISED ROAD NAMES

DATE: 9-08-17
HORZ. SCALE: 1" = 50'
VERT. SCALE: N/A
DRAWN BY: RLW
CHECKED BY: HSR
PROJECT NO.: 17-0398

MAGNETIC
(NO 30' PICKUP)

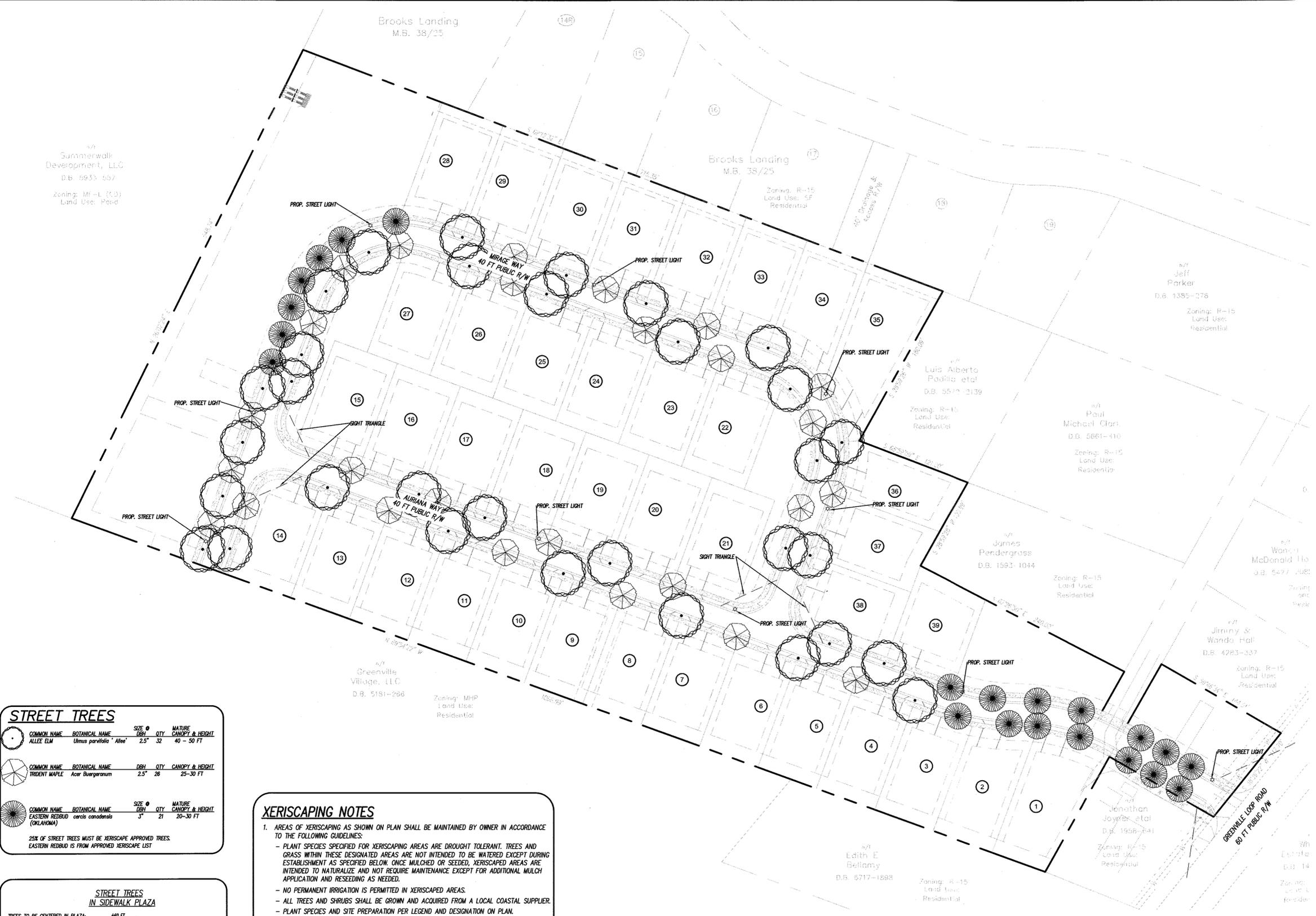

STREET TREES

COMMON NAME	BOTANICAL NAME	SIZE @ DBH	QTY	MATURE CANOPY & HEIGHT
ALLEE ELM	<i>Ulmus parvifolia 'Atter'</i>	2.5"	32	40 - 50 FT
TRIDENT MAPLE	<i>Acer buergerianum</i>	2.5"	26	25-30 FT
EASTERN REDBUD (OKLAHOMA)	<i>Cercis canadensis</i>	3"	21	20-30 FT

25% OF STREET TREES MUST BE XERISCAPE APPROVED TREES.
EASTERN REDBUD IS FROM APPROVED XERISCAPE LIST

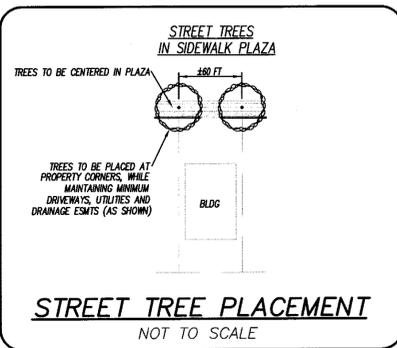

XERISCAPING NOTES

- AREAS OF XERISCAPING AS SHOWN ON PLAN SHALL BE MAINTAINED BY OWNER IN ACCORDANCE TO THE FOLLOWING GUIDELINES:
 - PLANT SPECIES SPECIFIED FOR XERISCAPING AREAS ARE DROUGHT TOLERANT. TREES AND GRASS WITHIN THESE DESIGNATED AREAS ARE NOT INTENDED TO BE WATERED EXCEPT DURING ESTABLISHMENT AS SPECIFIED BELOW. ONCE MULCHED OR SEEDING, XERISCAPED AREAS ARE INTENDED TO NATURALIZE AND NOT REQUIRE MAINTENANCE EXCEPT FOR ADDITIONAL MULCH APPLICATION AND RESEEDING AS NEEDED.
 - NO PERMANENT IRRIGATION IS PERMITTED IN XERISCAPED AREAS.
 - ALL TREES AND SHRUBS SHALL BE GROWN AND ACQUIRED FROM A LOCAL COASTAL SUPPLIER.
 - PLANT SPECIES AND SITE PREPARATION PER LEGEND AND DESIGNATION ON PLAN.
 - TREES ARE TO BE INSTALLED BETWEEN DECEMBER AND FEBRUARY. IF NOT INSTALLED DURING THIS TIME, "TREE GATOR" WATER BAGS (20 GALLON SIZE) ARE TO BE USED FOR EACH TREE AND TO BE FILLED ONCE PER WEEK FOR A PERIOD OF 6 MONTHS UNLESS 1" OF RAINFALL IS OCCURRING WITHIN EVERY SEVEN DAY PERIOD.
 - ALL AREAS DESIGNATED AS XERISCAPE SHALL BE MULCHED WITH LONGLEAF PINESTRAW, FREE OF DEBRIS, CONES, AND DIRT TO A DEPTH OF 4".
 - ALL TREES AND SHRUBS MUST BE MULCHED IMMEDIATELY AFTER PLANTING.
 - WHERE VEGETATED SWALES ARE REQUIRED THROUGH XERISCAPED AREAS, THE FOLLOWING PERMANENT SEED MIXTURE IS TO BE USED: 50%/ACRE PENSACOLA BAHIA GRASS, 5%/ACRE CENTIPEDE GRASS, 10%/ACRE GERMAN MILLET. SEEDING IS TO OCCUR DURING THE PERIOD APRIL 1 - JULY 15. USE SPECIFIED TEMPORARY SEEDING SCHEDULE TO SEED AT OTHER TIMES OF THE YEAR AND RESEED WITH PERMANENT SEEDING AT APPROPRIATE TIME. APPLY FERTILIZER AND LIME AS RECOMMENDED BY SOIL TEST.
- XERISCAPED AREAS SHALL REMAIN AS SUCH UNTIL PROPERTY IS REZONED DIFFERENTLY.

For each open utility cut of City streets, a \$325 permit shall be required from the City prior to occupancy and/or project acceptance.

Approved Construction Plan

Name: _____ Date: _____

Planning: _____

Traffic: _____

Fire: _____

CITY OF WILMINGTON
NORTH CAROLINA
Public Services • Engineering Division
APPROVED STORMWATER MANAGEMENT PLAN

Date: _____ Permit # _____

Signed: _____

1. TOTAL PROJECT AREA: 482,528 SF (11.08 AC.)
2. THIS SITE IS LOCATED WITHIN ZONE "X" ACCORDING TO FEMA FIRM COMMUNITY PANEL NUMBER 3720315600, EFFECTIVE DATE 4/3/06
3. AS-BUILT, BOUNDARY AND TOPOGRAPHIC SURVEY PERFORMED AND PROVIDED TO CSD ENGINEERING BY (GE)INNOVATION, PC VERTICAL DATUM = 88
4. STORMWATER DRAINS TO BRADLEY CREEK, SC 18-87-24-4(2)

SCALE IN FEET: 1" = 50'

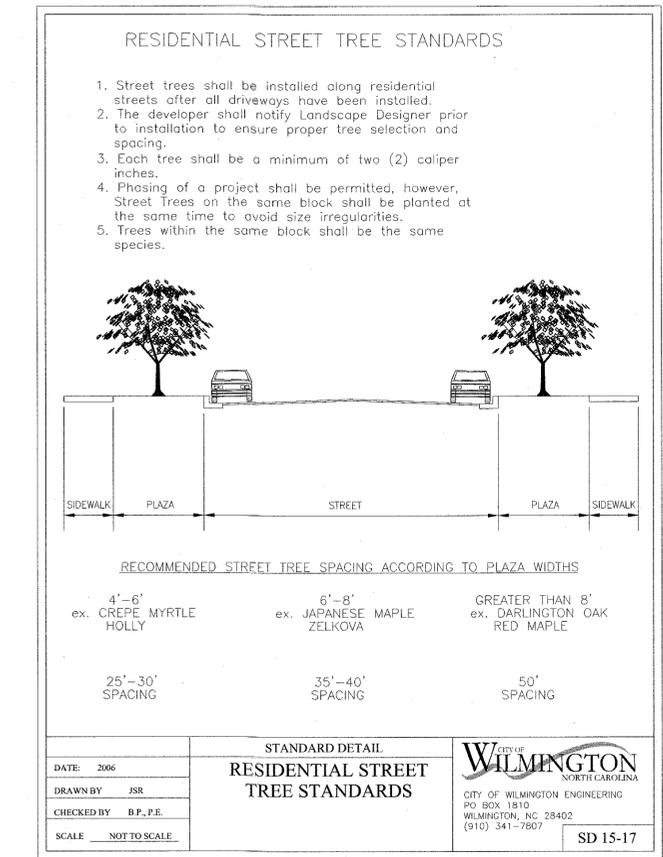
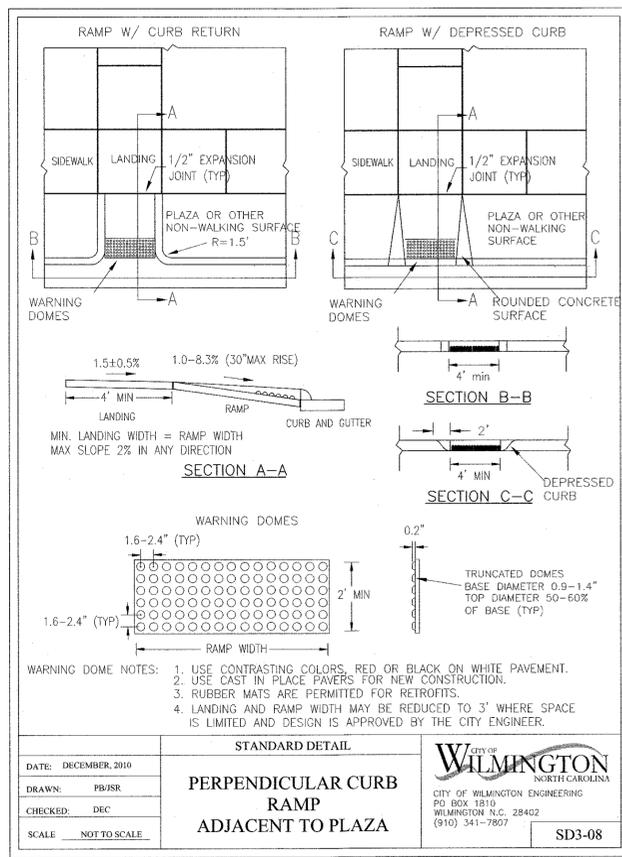
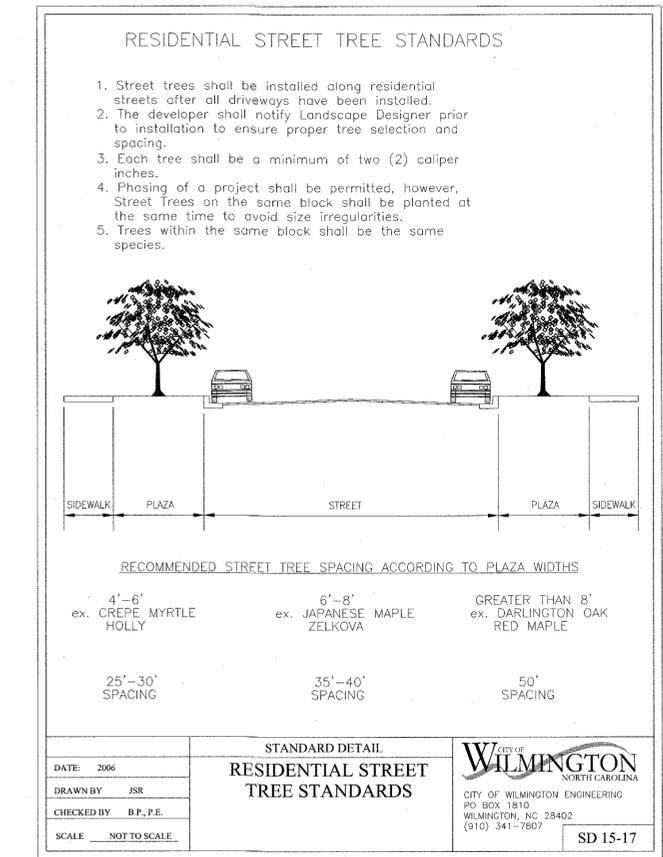
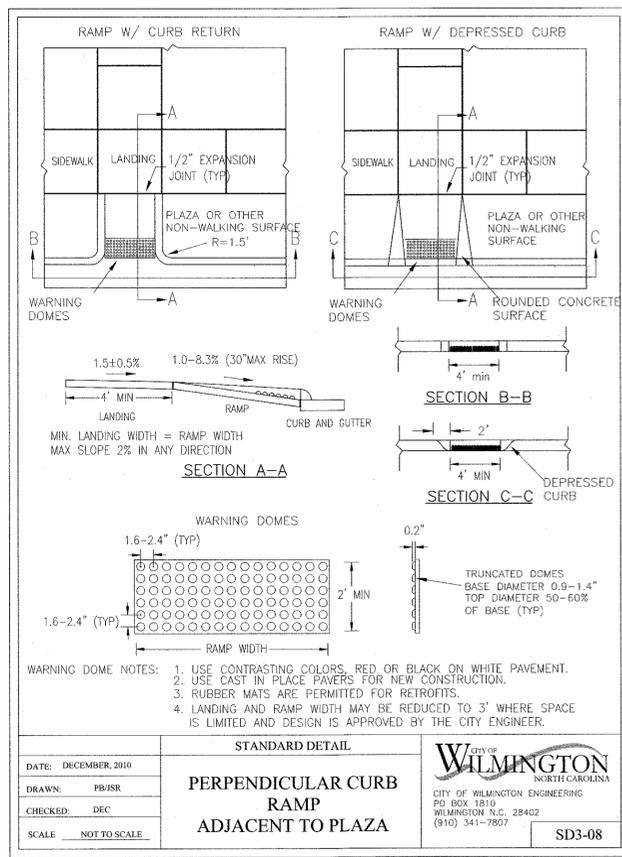
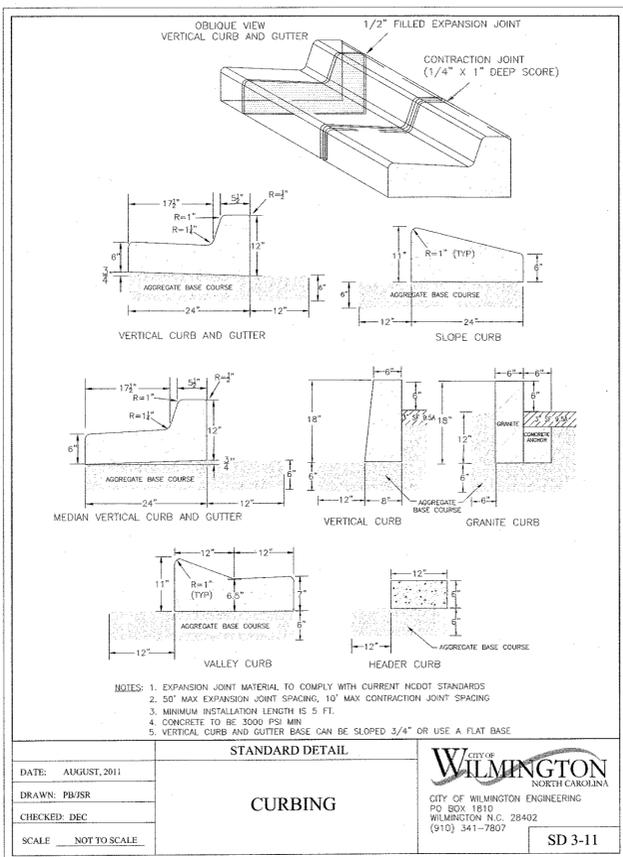
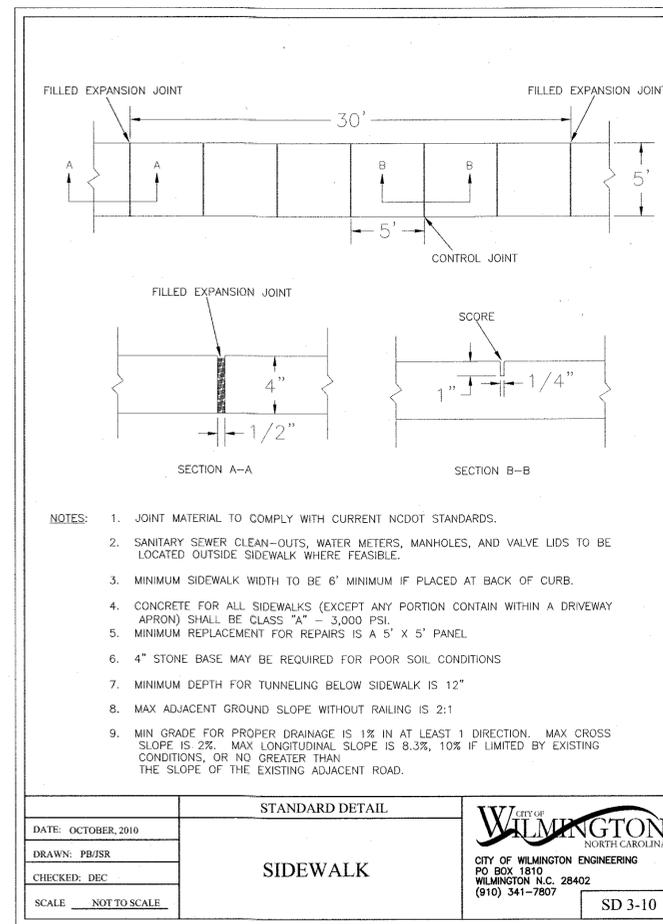
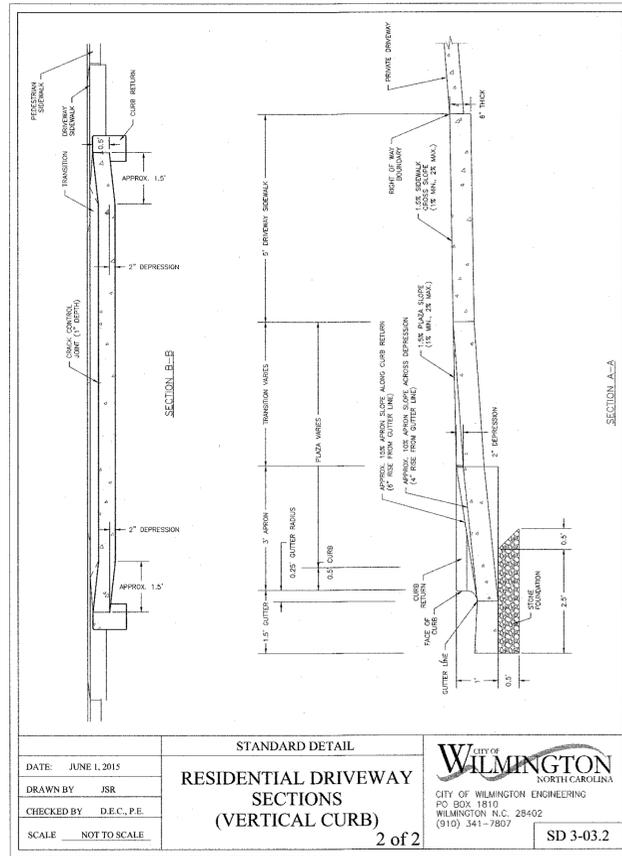
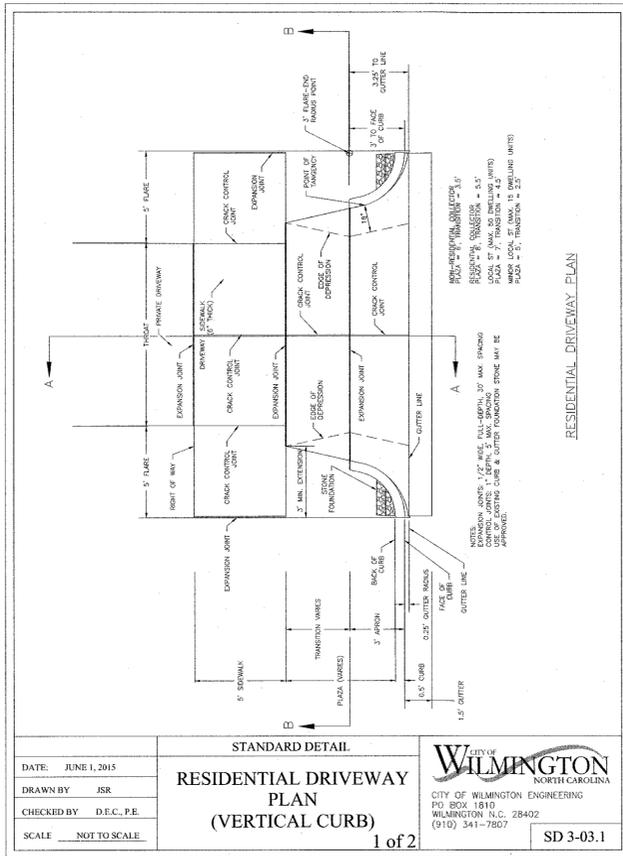

CSD ENGINEERING
 LICENSE # C-2710
 ENGINEERING
 LAND PLANNING
 COMMERCIAL / RESIDENTIAL
 P.O. BOX 4041
 WILMINGTON, NC 28406
 (910) 791-4441

SITE PLAN DETAILS for
PACIFIC PLACE

SITE PLAN for
PACIFIC PLACE
 LOCATED IN CITY OF WILMINGTON
 NEW HANOVER COUNTY, NORTH CAROLINA
 OWNER: ARVIA HOLDINGS, LLC
 PO BOX 3122
 WILMINGTON, NC 28406

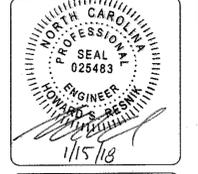

DATE	BY	REMARKS
1/15/18	HSR	
12/11/17	RLW	
9/08/17	JSM	

For each open utility cut of City streets, a \$325 permit shall be required from the City prior to occupancy and/or project acceptance.

Approved Construction Plan
 Name: _____ Date: 1/17/18
 Planning: _____
 Traffic: _____
 Fire: C. Webb 1/19/18

CITY OF WILMINGTON
 NORTH CAROLINA
 Public Services • Engineering Division
 APPROVED STORMWATER MANAGEMENT PLAN
 Date: 1/18/18 Permit # 20180006
 Signed: RLW

DATE: 7-12-17
 HORIZ. SCALE: N/A
 VERT. SCALE: N/A
 DRAWN BY: RLW
 CHECKED BY: HSR
 PROJECT NO.: 17-0398

NOTE:
THE CRITICAL ROOT ZONE (CRZ) OF A TREE IS WHERE THE MAJORITY OF A TREE'S ROOTS LAY. 85% OF MOST TREE ROOTS ARE FOUND IN THE TOP 24" OF THE SOIL AND SUPPLY THE MAJORITY OF NUTRIENTS AND WATER. GENERALLY, ROOTS SPREAD OUT 2-3X THE HEIGHT OF THE TREE.

NOTE:
CROWN OF THE TREE IS NEEDED FOR LEAF GROWTH TO PRODUCE OXYGEN, FILTER THE AIR, REDUCE WIND AND SOFTEN NOISE. DO NOT DISFIGURE CROWN WITH INTENSIVE PRUNING.

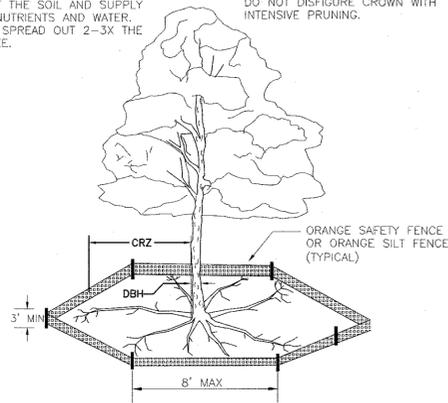

- NOTES:
1. PROTECT CRITICAL ROOT ZONE (CRZ) OF TREES PRIOR TO CONSTRUCTION. CLEARLY MARK THE TREES AND ERECT A PROTECTIVE BARRIER AT THE CRZ. BARRIER SHALL BE MAINTAINED UNTIL CONSTRUCTION IS COMPLETE.
 2. CRZ RADIUS IS 1 FT PER INCH OF TREE DIAMETER AT BREAST HEIGHT (DBH).
 3. IF CONSTRUCTION OCCURS WITHIN THE CRZ, AT LEAST 12" OF MULCH AND/OR LOGGING MATTS SHALL BE PLACED WHERE MACHINERY MANEUVERS TO REDUCE SOIL COMPACTION IN THIS ZONE.
 4. WHERE SIDEWALKS AND PATHWAYS PASS WITHIN CRZ, EXTRA CARE SHALL BE TAKEN TO AVOID DAMAGE TO THE ROOTS. ALTERNATE CONSTRUCTION METHODS, SUCH AS A REINFORCED SIDEWALK, SHALL BE IMPLEMENTED AS NECESSARY.
 5. FOR ALL TREES, CUTTING OF LARGE STRUCTURAL ROOTS LOCATED NEAR THE BASE OF THE TRUNK IS PROHIBITED. DO NOT COMPACT SOIL BENEATH TREES. NO VEHICLE SHALL BE ALLOWED TO PARK UNDER TREES. NO MATERIALS OR EQUIPMENT SHALL BE STORED BENEATH TREES. DAMAGING THE BARK WITH LAWNMOWERS, CONSTRUCTION EQUIPMENT, OR ANYTHING ELSE IS PROHIBITED. CONTRACTOR SHALL REPAIR DAMAGE TO TREES.
 6. FAILING TO INSTALL OR MAINTAIN PROTECTION MEASURES SHALL RESULT IN A STOP WORK ORDER AND FINE OF \$500/DAY. DISTURBANCE OTHER THAN THAT ALLOWED ON THE APPROVED PLAN WILL REQUIRE OWNER TO POST A LETTER OF CREDIT FOR 3 YRS FOR TREE MITIGATION.

DATE: JAN, 2015	STANDARD DETAIL	<p>CITY OF WILMINGTON ENGINEERING PO BOX 1810 WILMINGTON, NC 28402 (910) 341-7807</p>	SD 15-09
DRAWN BY JSR	TREE PROTECTION DURING CONSTRUCTION		SHEET 1 of 2
CHECKED BY RDG, P.E.			
SCALE NOT TO SCALE			

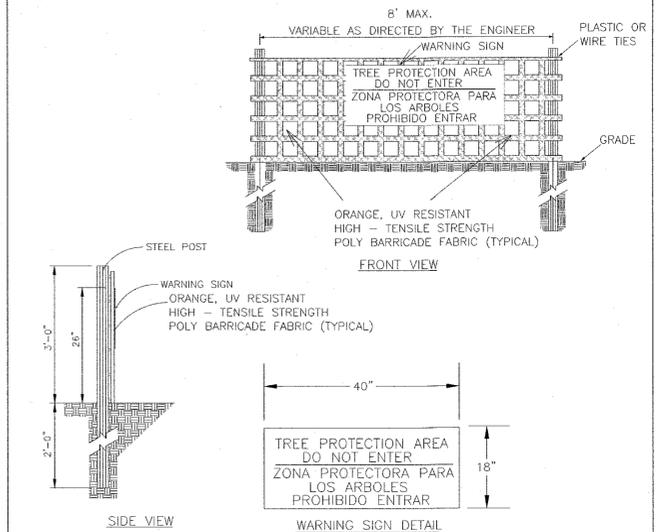

- NOTES:
1. THE TREE PROTECTION FENCING SHALL NOT BE VIOLATED FOR THE ENTIRE DURATION OF THE PROJECT WITHOUT APPROVAL FROM URBAN FORESTRY STAFF.
 2. WARNING SIGNS TO BE MADE OF DURABLE, WEATHERPROOF MATERIAL. LETTERS TO BE 3" HIGH, MINIMUM, CLEARLY LEGIBLE AND SPACED AS DETAILED.
 3. SIGNS SHALL BE PLACED AT 50' MAXIMUM INTERVALS. PLACE A SIGN AT EACH END OF LINEAR TREE PROTECTION AND 50' ON CENTER THEREAFTER. FOR TREE PROTECTION AREAS LESS THAN 100' IN PERIMETER, PROVIDE NO LESS THAN TWO SIGNS PER PROTECTION AREA.
 4. ATTACH SIGNS SECURELY TO FENCE POSTS AND FABRIC. MAINTAIN TREE PROTECTION FENCE AND SIGNS THROUGHOUT DURATION OF PROJECT.
 5. TREE PROTECTION FENCING AND SIGNAGE SHALL BE REMOVED AFTER CONSTRUCTION.
 6. ADDITIONAL SIGNS MAY BE REQUIRED BY CITY OF WILMINGTON, BASED ON ACTUAL FIELD CONDITIONS.

DATE: JAN, 2015	STANDARD DETAIL	<p>CITY OF WILMINGTON ENGINEERING PO BOX 1810 WILMINGTON, NC 28402 (910) 341-7807</p>	SD 15-09
DRAWN BY JSR	TREE PROTECTION DURING CONSTRUCTION		SHEET 2 of 2
CHECKED BY RDG, P.E.			
SCALE NOT TO SCALE			

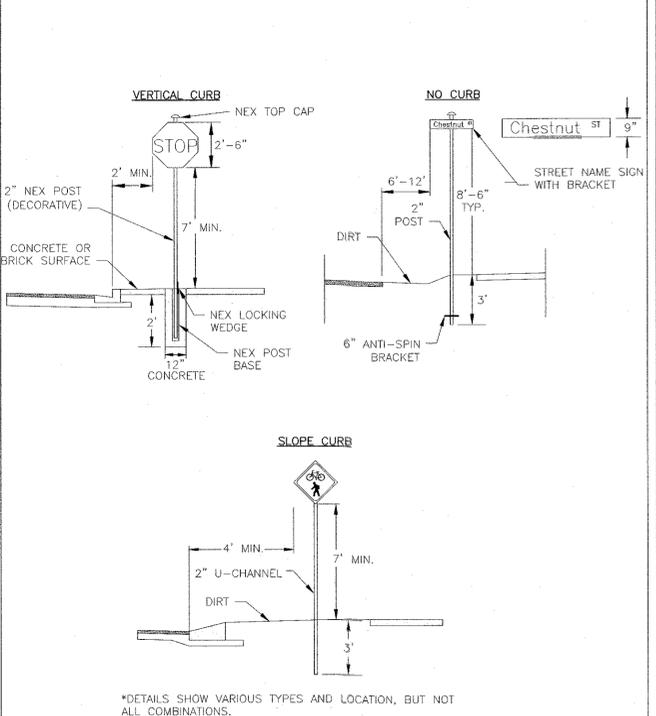

DATE: NOVEMBER, 2011	STANDARD DETAIL	<p>CITY OF WILMINGTON ENGINEERING PO BOX 1810 WILMINGTON, NC 28402 (910) 341-7807</p>	SD 15-03
DRAWN BY JSR	STREET SIGNS AND LOCATION		SHEET 1 of 2
CHECKED BY BDR, P.E.			
SCALE NOT TO SCALE			

- SIGNS**
1. All signs shall meet the requirements of MUTCD and City Traffic Engineering in effect at the time of construction.
 2. All Traffic Control Signs including multi-use paths shall be fabricated with 0.080 inch aluminum blanks using high intensity prismatic reflective sheeting Type IV or better. STOP signs shall be a minimum of 30"x30".
 3. SPECIAL DESIGNATION signs by location and type shall adhere to City of Wilmington signage plan (i.e. downtown, historic, cross-city trail, parks, riverfront, scenic by-way, parking, etc.) and all associated policies.
 4. POST MOUNTED STREET NAME SIGNS shall be fabricated with 9" extruded aluminum street name sign blanks using a standard cut-out. Minimum sign length is 18" long and increasing in 6" increments to 54" maximum as dictated by the number of letters in the name. The color scheme shall be white letters on a green background without a border. Generally, in the downtown and historic areas or as designated in the City of Wilmington signage plan the background shall be blue and contain a topper.
 5. Decorative sign posts shall consist of the NEX sign support system, 2" octagonal tube, 14 gauge, powder coated glossy black and include cap, post, base and wedge.
 6. All other sign posts shall be u-channel posts made of galvanized steel with 8" posts 2lbs/ft or 12" posts 3lbs/ft. Galvanized NEX post may be substituted with approval from the City Signs and Markings Engineer.
 7. OVERHEAD STREET NAME SIGNS shall be fabricated with 0.080 inch aluminum flat sign blanks 18" in height using a standard cut-out. Sign length will be dictated by the number of letters in the name. For mast-arm type traffic signal supports and other overhead support systems refer to the design plans for maximum sign length.
 8. All sign lettering, colors and fonts shall adhere to the MUTCD in effect at the time of construction. Fluorescent Yellow-Green shall be used on signs, in place of Yellow, when listed as an optional color in the MUTCD. Generally, the font will be FHWA series fonts (Highway Gothic.) Other font types require prior City Signs and Markings Engineer approval.
- LOCATION**
9. Sign locations depend on the edge of road condition. Generally, signs shall be a minimum 2' from face of a vertical curb, 4' from front of slope face curb, and 6' from edge of pavement without curb. Signs shall not be located more than 12' from any of these locations.
 10. Sign posts installed in dirt shall be buried a minimum of 36". Octagonal posts shall utilize an anti-spin device, 6" in length minimum. Sign posts installed in concrete or brick shall utilize a base cast in concrete 24" x 12" diameter.
 11. Street name signs shall be installed 8'-6" from the ground to the bottom of the sign. Street name signs co-located with STOP signs shall be installed above the STOP sign. A 6" space shall be maintained between the STOP sign and a Street name sign that is parallel to the STOP sign face. All other signs should be mounted per MUTCD guidelines for Urban Areas.

DATE: NOVEMBER, 2011	STANDARD DETAIL	<p>CITY OF WILMINGTON ENGINEERING PO BOX 1810 WILMINGTON, NC 28402 (910) 341-7807</p>	SD 15-03
DRAWN BY JSR	STREET SIGNS AND LOCATION		SHEET 2 of 2
CHECKED BY BDR, P.E.			
SCALE NOT TO SCALE			



LICENSE # C-2710
ENGINEERING
LAND PLANNING
COMMERCIAL / RESIDENTIAL
P.O. BOX 4041
WILMINGTON, NC 28406
(910) 791-4441

SITE PLAN DETAILS for
PACIFIC PLACE

LOCATED IN CITY OF WILMINGTON
NEW HANOVER COUNTY, NORTH CAROLINA
OWNER: ARYA HOLDINGS, LLC
PO BOX 3122
WILMINGTON, NC 28406



REV. NO.	DATE	BY	REMARKS
3	1/15/18	MSR	PLOTTED FOR CITY SIGNATURES
2	12/17/17	RLW	ADDED CDM STAMPS
1	9/28/17	CSM	REVISED SHEET NUMBERS

For each open utility cut of City streets, a \$325 permit shall be required from the City prior to occupancy and/or project acceptance.

Approved Construction Plan

Name: _____ Date: 4/17/18

Planning: _____

Traffic: W. Swados 1/7/18

Fire: C. White 1/9/18

DATE: 7-12-17	HORIZ. SCALE: N/A	VERT. SCALE: N/A
DRAWN BY: RLW	CHECKED BY: HSR	PROJECT NO.: 17-0398
Date: 1/13/18	Permit # 2018006	Signed: [Signature]

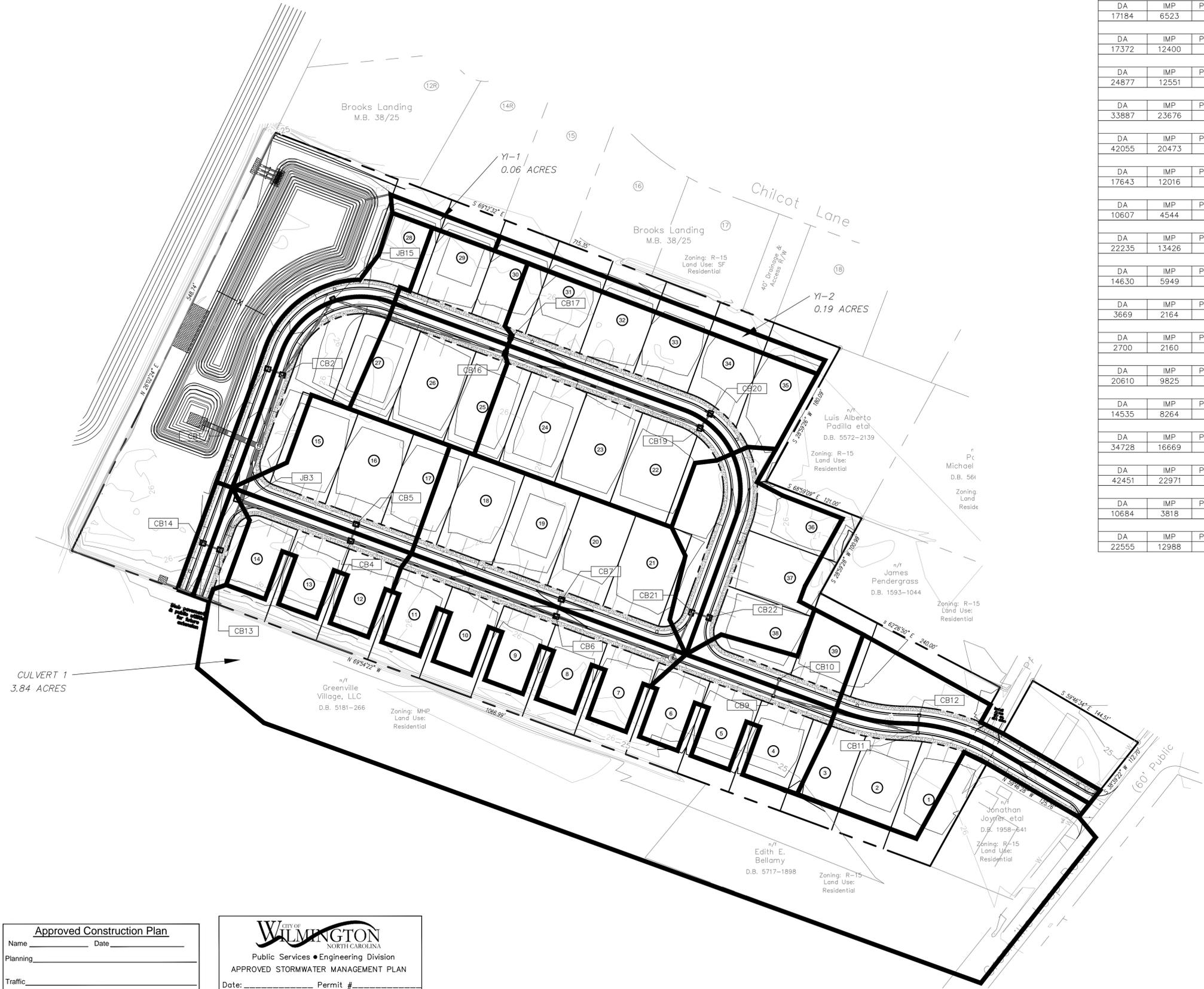

CB 1					
DA	IMP	Pervious	C Imp	C Pervious	C Value
12101	8589	3512	0.95	0.15	0.72
CB 2					
DA	IMP	Pervious	C Imp	C Pervious	C Value
17184	6523	10661	0.95	0.15	0.45
CB 4					
DA	IMP	Pervious	C Imp	C Pervious	C Value
17372	12400	4972	0.95	0.15	0.72
CB 5					
DA	IMP	Pervious	C Imp	C Pervious	C Value
24877	12551	12326	0.95	0.15	0.55
CB 6					
DA	IMP	Pervious	C Imp	C Pervious	C Value
33687	23676	10211	0.95	0.15	0.71
CB 7					
DA	IMP	Pervious	C Imp	C Pervious	C Value
42055	20473	21582	0.95	0.15	0.54
CB 9					
DA	IMP	Pervious	C Imp	C Pervious	C Value
17643	12016	5627	0.95	0.15	0.69
CB 10					
DA	IMP	Pervious	C Imp	C Pervious	C Value
10607	4544	6063	0.95	0.15	0.49
CB 11					
DA	IMP	Pervious	C Imp	C Pervious	C Value
22235	13426	8809	0.95	0.15	0.63
CB 12					
DA	IMP	Pervious	C Imp	C Pervious	C Value
14630	5949	8681	0.95	0.15	0.48
CB 13					
DA	IMP	Pervious	C Imp	C Pervious	C Value
3669	2164	1505	0.95	0.15	0.62
CB 14					
DA	IMP	Pervious	C Imp	C Pervious	C Value
2700	2160	540	0.95	0.15	0.79
CB 16					
DA	IMP	Pervious	C Imp	C Pervious	C Value
20610	9825	10785	0.95	0.15	0.53
CB 17					
DA	IMP	Pervious	C Imp	C Pervious	C Value
14535	8264	6271	0.95	0.15	0.60
CB 19					
DA	IMP	Pervious	C Imp	C Pervious	C Value
34728	16669	18059	0.95	0.15	0.53
CB 20					
DA	IMP	Pervious	C Imp	C Pervious	C Value
42451	22971	19480	0.95	0.15	0.58
CB 21					
DA	IMP	Pervious	C Imp	C Pervious	C Value
10684	3818	6866	0.95	0.15	0.44
CB 22					
DA	IMP	Pervious	C Imp	C Pervious	C Value
22555	12988	9567	0.95	0.15	0.61

CULVERT 1
3.84 ACRES

For each open utility cut of City streets, a \$325 permit shall be required from the City prior to occupancy and/or project acceptance.

Approved Construction Plan

Name _____ Date _____

Planning _____

Traffic _____

Fire _____

CITY OF WILMINGTON
NORTH CAROLINA

Public Services • Engineering Division

APPROVED STORMWATER MANAGEMENT PLAN

Date: _____ Permit # _____

Signed: _____



CSD ENGINEERING

LICENSE # C-2710
ENGINEERING
LAND PLANNING
COMMERCIAL / RESIDENTIAL

P.O. BOX 4041
WILMINGTON, NC 28406
(910) 791-4441

INLET DRAINAGE AREA
PACIFIC PLACE

INLET DRAINAGE AREA
PACIFIC PLACE
LOCATED IN CITY OF WILMINGTON
NEW HANOVER COUNTY, NORTH CAROLINA
OWNER: ARYA HOLDINGS, LLC
P.O. BOX 3172
WILMINGTON, NC 28406

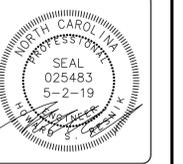

REV. NO.	DATE	BY	REMARKS
3	5/2/19	MRB	REVISED PER NEW LOT LAYOUT
2	12/1/17	RLW	ADDED COW STAMPS
1	10/9/17	RLW	TURND TABLE ON

DATE: 7-18-17
HORZ. SCALE: 1" = 60'
VERT. SCALE: N/A
DRAWN BY: RLW
CHECKED BY: HSR
PROJECT NO.: 17-0398

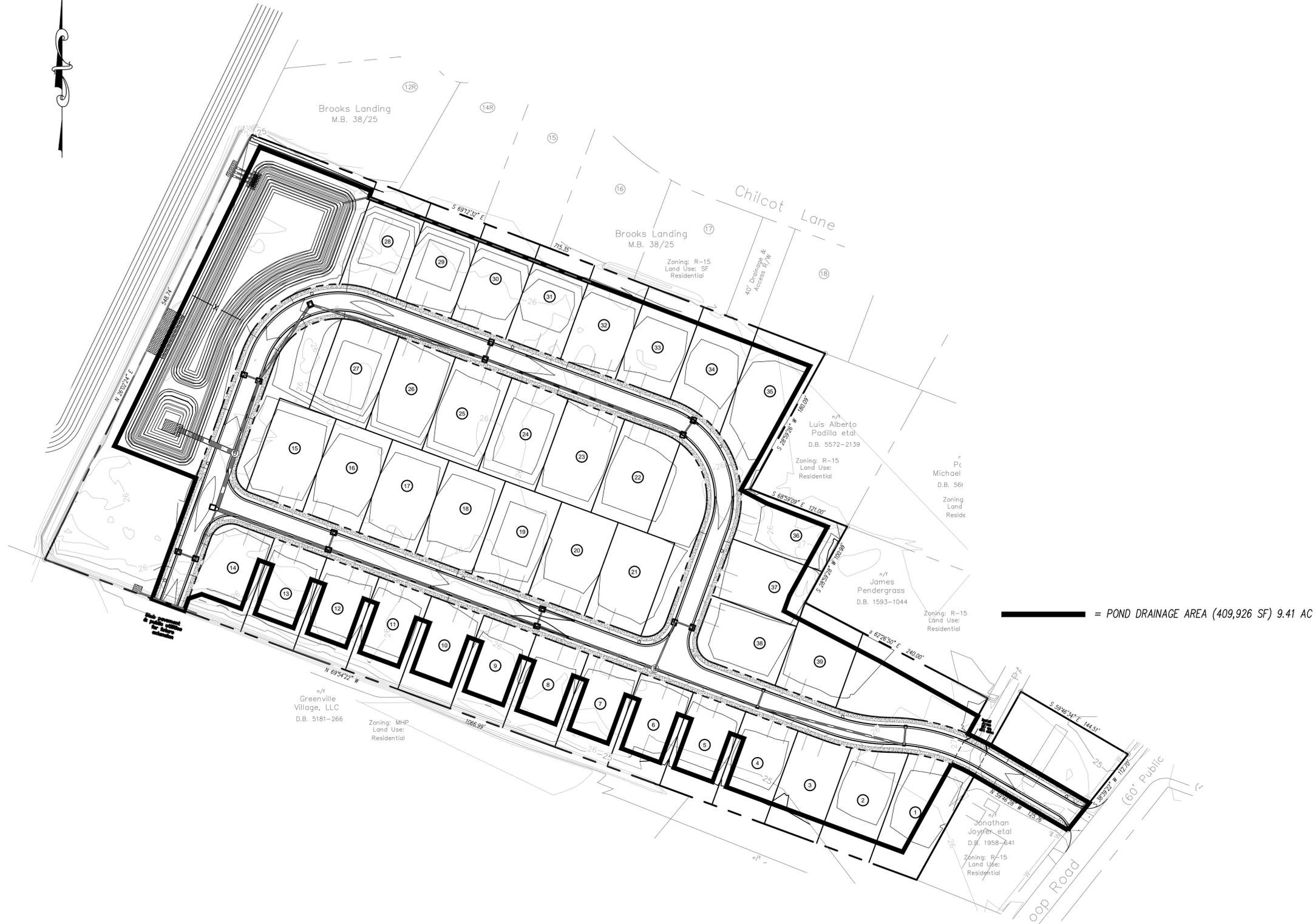

— = POND DRAINAGE AREA (409,926 SF) 9.41 AC

For each open utility cut of City streets, a \$325 permit shall be required from the City prior to occupancy and/or project acceptance.

Approved Construction Plan

Name _____ Date _____

Planning _____

Traffic _____

Fire _____

CITY OF WILMINGTON
NORTH CAROLINA

Public Services • Engineering Division

APPROVED STORMWATER MANAGEMENT PLAN

Date: _____ Permit # _____

Signed: _____



LICENSE # C-2710
ENGINEERING
LAND PLANNING
COMMERCIAL / RESIDENTIAL

P.O. BOX 4041
WILMINGTON, NC 28406
(910) 791-4441

POND DRAINAGE AREA
PACIFIC PLACE

POND DRAINAGE AREA
PACIFIC PLACE
LOCATED IN CITY OF WILMINGTON
NEW HANCOCK COUNTY, NORTH CAROLINA
OWNER: ARYA HOLDINGS, LLC
P.O. BOX 3172
WILMINGTON, NC 28406



REV. NO.	DATE	BY	REMARKS
3	5/2/19	MRB	REVISED PER NEW LOT LAYOUT
2	12/1/17	RLW	ADDED COW STAMPS
1	10/9/17	RLW	REVISED DRAINAGE AREA

DATE: 7-18-17
HORZ. SCALE: 1" = 60'
VERT. SCALE: N/A
DRAWN BY: RLW
CHECKED BY: HSR
PROJECT NO.: 17-0398

LOCATION MAP

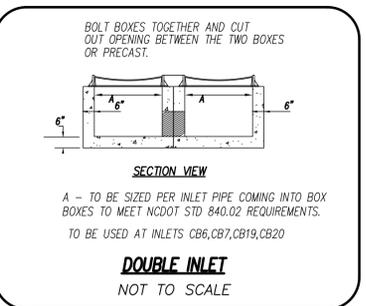
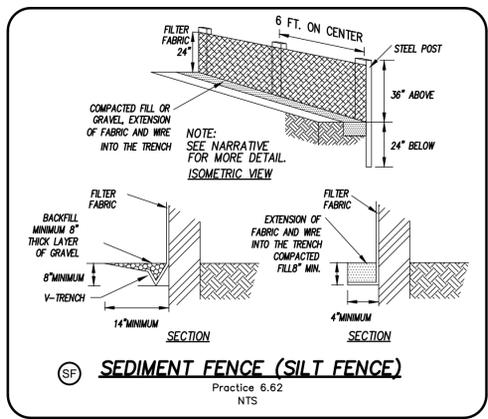
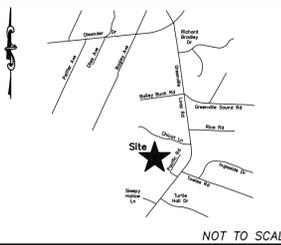

TEMPORARY SEDIMENT BASIN SUMMARY:
MIN. BASIN VOL. = 1,800 CF/ACRE DISTURBED AREA (10 YR. STORM)
 $Q = (0.37)(A)$
 $SA = Q \times 3.25$
(SEDIMENT MUST BE REMOVED TWICE A YEAR)

SEDIMENT BASIN	DRAINAGE AREA (ACRES)	DISTURBED AREA (ACRES)	MINIMUM VOLUME (CF)	VOLUME PROVIDED (CF)	10 YR FLOW (CFS)	MIN SURFACE AREA (SF)	SURFACE AREA PROVIDED (SF)	SKIMMER SIZE	SKIMMER OVERSIZE
1	9.41	9.41	16,838	50,287	27.38	8,899	18,855	4 IN	3.6 IN

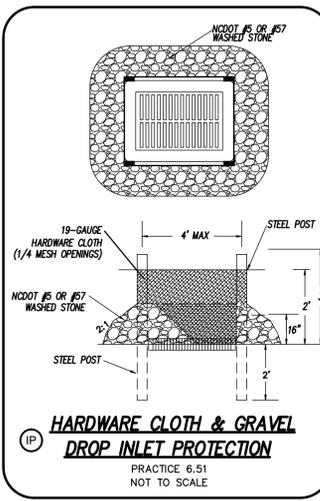

- CONSTRUCTION SCHEDULE -**
- OBTAIN APPROVAL OF PLAN AND ANY NECESSARY PERMITS, AND HOLD A PRE-CONSTRUCTION CONFERENCE PRIOR TO COMMENCING ANY WORK.
 - FLAG WORK LIMITS AND STAKE-OUT PARKING LOT AND STORM DRAINAGE STRUCTURES FOR PRELIMINARY GRADING.
 - INSTALL GRAVEL CONSTRUCTION ENTRANCES.
 - INSTALL SILT FENCING PRIOR TO ROUGH GRADING THE REMAINING SITE AND ANY STOCKPILING OF MATERIAL AND TOPSOIL NECESSARY.
 - CONSTRUCT SWALES, GRASS LINED CHANNELS, SEDIMENT TRAPS & BASINS AND ANY OTHER SEDIMENT CONTROL PRACTICES SHOWN, PRIOR TO ROUGH GRADING ROADWAYS AND SITE, STOCKPILING TOPSOIL AS NECESSARY.
 - INSTALL UTILITIES IN ROADWAY, ESTABLISH FINAL ROAD GRADES AND STABLE ROAD WITH STONE BASE COURSE.
 - FINAL GRADE, INSTALL NON-MUNICIPAL UTILITIES AS NEEDED, AND VEGETATIVELY STABILIZE AREAS WHERE BUILDING CONSTRUCTION IS NOT IMMINENT.
 - ALL EROSION AND SEDIMENT CONTROL PRACTICES ARE TO BE INSPECTED NEARLY AND AFTER ANY RAINFALL, AND REPAIRED AS NECESSARY.
 - UPON COMPLETION OF CONSTRUCTION, THE ROADWAY IS TO BE PAVED AND ALL AREAS PERMANENTLY VEGETATIVELY STABILIZED. AFTER SITE STABILIZATION, TEMPORARY MEASURES ARE TO BE REMOVED.
- MAINTENANCE PLAN -**
- ALL EROSION AND SEDIMENT CONTROL MEASURES WILL BE CHECKED FOR STABILITY AND OPERATION FOLLOWING EVERY RAINFALL, BUT IN NO CASE, LESS THAN ONCE EVERY WEEK AND WITHIN 24 HOURS OF EVERY 0.5" RAINFALL.
 - ALL POINTS OF EGRESS SHALL HAVE CONSTRUCTION ENTRANCES THAT WILL PERIODICALLY TOP-DRESS WITH AND ADDITIONAL 2 INCHES OF #4 STONE TO MAINTAIN PROPER DEPTH. THEY WILL BE MAINTAINED IN A CONDITION TO ALLOW FOR SEDIMENT FROM LEAVING THE SITE. IMMEDIATELY REMOVE OBJECTIONABLE MATERIAL SPILLED, WASHED OR TRACKED ONTO THE CONSTRUCTION ENTRANCE OR ROADWAYS.
 - SEDIMENT WILL BE REMOVED FROM HARDWARE CLOTH AND GRAVEL INLET PROTECTION, BLOCK AND GRAVEL INLET PROTECTION, ROCK DOUGHNUT INLET PROTECTION AND ROCK PIPE INLET PROTECTION WHEN THE DESIGNED STORAGE CAPACITY HAS BEEN HALF FILLED WITH SEDIMENT. ROCK WILL BE CLEANED OR REPLACED WHEN THE SEDIMENT POOL NO LONGER DRAINS AS DESIGNED. DEBRIS WILL BE REMOVED FROM LEAVING THE CONSTRUCTION SITE. SILT SACKS WILL BE EMPTIED ONCE A WEEK AND AFTER EVERY RAIN EVENT. SEDIMENT WILL BE REMOVED FROM AROUND WATTLERS, BEAVER DAMS, DANDY SACKS AND SACKS ONCE A WEEK AND AFTER RAIN EVENT. DIVERSION DITCHES WILL BE CLEANED OUT IMMEDIATELY TO REMOVE SEDIMENT OR OBSTRUCTIONS FROM THE FLOW AREA. THE DIVERSION RIDGES WILL ALSO BE REPAIRED. SWALES MUST BE TEMPORARILY STABILIZED WITHIN 21 CALENDAR DAYS OF CEASE OF ANY PHASE OF ACTIVITY ASSOCIATED WITH A SWALE.
 - SEDIMENT WILL BE REMOVED FROM BEHIND THE SEDIMENT FENCE WHEN IT BECOMES HALF FILLED. THE SEDIMENT FENCE WILL BE REPAIRED AS NECESSARY TO MAINTAIN A BARRIER. STAKE SPACING WILL BE 6 FEET MAX. WITH THE USE OF EXTRA STRENGTH FABRIC, WITHOUT WIRE BACKING. STAKE SPACING WILL BE 8 FEET MAX. WHEN STANDARD STRENGTH FABRIC AND WIRE BACKING ARE USED. IF ROCK FILTERS ARE DESIGNED AT LOW POINTS IN THE SEDIMENT FENCE, THE ROCK WILL BE REPAIRED OR REPLACED IF IT BECOMES HALF FULL OF SEDIMENT, NO LONGER DRAINS AS DESIGNED OR IS DAMAGED.
 - SEDIMENT WILL BE REMOVED FROM SEDIMENT TRAPS WHEN THE DESIGNED STORAGE CAPACITY HAS BEEN HALF FILLED WITH SEDIMENT. THE ROCK WILL BE CLEANED OR REPLACED WHEN THE SEDIMENT POOL NO LONGER DRAINS OR WHEN THE ROCK IS DISLOADED. BATTERIES WILL BE REPAIRED OR REPLACED IF THEY COLLAPSE, TEAR, DECOMPOSE, OR BECOME INEFFECTIVE. THEY WILL BE REPLACED PROMPTLY. SEDIMENT WILL BE REMOVED WHEN DEPOSITS REACH HALF THE HEIGHT OF THE 1ST BATTLE. BATTERIES WILL BE REPAIRED OR REPLACED IF THEY COLLAPSE, TEAR, DECOMPOSE, OR BECOME INEFFECTIVE. THEY WILL BE REPLACED PROMPTLY. SEDIMENT WILL BE REMOVED FROM BATTERIES WHEN DEPOSITS REACH HALF THE HEIGHT OF THE 1ST BATTLE. FLOATING SUMMERS WILL BE INSPECTED NEARLY AND WILL BE KEPT CLEAN.
 - ALL SEEDS ARE TO BE FERTILIZED, RESEED AS NECESSARY AND MULCHED ACCORDING TO THE SPECIFICATIONS IN THE VEGETATION PLAN TO MAINTAIN A VIGOROUS, DENSE VEGETATIVE COVER. ALL SLOPES WILL BE STABILIZED WITHIN 21 CALENDAR DAYS. ALL OTHER AREAS WILL BE STABILIZED WITH 15 WORKING DAYS.
 - FLOODLIGHTS WILL BE USED TO ADDRESS TURBIDITY ISSUES. THE PUMPS, TANKS, HOSES AND INJECTION SYSTEMS WILL BE CHECKED FOR PROBLEMS OR TURBID DISCHARGES DAILY. INSPECT CHECK DAMS AND CHANNELS AT LEAST WEEKLY AND AFTER EACH SIGNIFICANT RAINFALL EVENT AND REPAIR IMMEDIATELY. CLEAN OUT SEDIMENT, STRAIN, LIMBS, OR OTHER DEBRIS THAT COULD CLOG THE CHANNEL WHEN NEEDED.
- VEGETATION PLAN -**
- PERMANENT VEGETATION TO BE ESTABLISHED IN ACCORDANCE WITH NORTH CAROLINA EROSION AND SEDIMENT CONTROL PLANNING AND DESIGN MANUAL, SECTION 6.11, LATEST VERSION.

CSD ENGINEERING
LICENSE # C-2710
ENGINEERING
LAND PLANNING
COMMERCIAL / RESIDENTIAL

P.O. BOX 4041
WILMINGTON, NC 28406
(910) 791-4441

- PLANNED EROSION AND SEDIMENT CONTROL PRACTICES -**
- TEMPORARY GRAVEL CONSTRUCTION ENTRANCE**
Practice 6.06
SHALL BE INSTALLED AT THE ENTRANCES TO THE PROJECT FROM AN EXISTING ROADWAY. DRAINAGE SHOULD BE AWAY FROM THE ROAD AND EROSION WILL BE CONTROLLED WITH DOWNSTREAM PRACTICES. DURING WET WEATHER IT MAY BE NECESSARY TO WASH TRUCK TIRES AT THESE LOCATIONS.
 - LAND GRADING**
Practice 6.02
GRADING SHOULD BE LIMITED TO AREAS AS SHOWN ON THE PLANS. CUT AND FILL SLOPES SHALL BE 3:1 OR FLATTER EXCEPT WHERE SPECIALLY INDICATED. CARE SHALL BE TAKEN DURING LAND GRADING ACTIVITIES NOT TO DAMAGE EXISTING TREES THAT ARE IDENTIFIED AS "TO BE PRESERVED".
 - SEDIMENT FENCE**
Practice 6.62
SEDIMENT FENCING SHOULD BE INSTALLED AS SHOWN ON THE PLAN, TO DELINEATE AND PROTECT WETLANDS AND NECESSARY AREAS, AND AROUND ANY TEMPORARY STOCKPILE AREAS AS NECESSARY TO PREVENT ANY GRADED INTERIOR AREAS FROM ERODING ONTO ADJACENT LANDS OR ROADWAY, OR INTO INLETS, OR AS DIRECTED BY ENGINEER OR NEW HAMOVER COUNTY EROSION CONTROL PERSONNEL.
 - CONSTRUCTION ROAD STABILIZATION**
Practice 6.80
UPON REACHING FINAL GRADE AND AFTER UTILITIES HAVE BEEN INSTALLED, ROADWAY/PARKING AREAS ARE TO BE STABILIZED BY PLACING SUB-BASE AS SHOWN IN THE TYPICAL STREET CROSS-SECTION DETAIL ON THE PLAN, TO REDUCE EROSION AND DUST DURING THE REMAINDER OF BUILDING CONSTRUCTION.
 - SEDIMENT BASIN**
Practice 6.01
THE SEDIMENT BASIN IS TO BE CONSTRUCTED FIRST (SEE CONSTRUCTION SCHEDULE) AND IS THE PRIMARY PRACTICE TO PREVENT SEDIMENT FROM LEAVING THE SITE. DETAILED DESIGN AND CONSTRUCTION CONFIGURATIONS ARE SPECIFIED IN THE DETAIL SHEET.
 - SKIMMER**
Practice 6.64
A SEDIMENTATION BASIN DRAINAGE CONTROL DEVICE THAT WITHDRAWS WATER FROM THE BASIN WATER SURFACE, THUS REMOVING THE HIGHEST QUALITY WATER FOR DELIVERY TO THE UNCONTROLLED ENVIRONMENT.
 - BAFFLE**
Practice 6.65
A POROUS BARRIER INSTALLED INSIDE A TEMPORARY SEDIMENT TRAP, SKIMMER BASIN OR SEDIMENT BASIN TO REDUCE THE VELOCITY AND TURBULENCE OF WATER FLOWING THROUGH THE MEASURE AND TO FACILITATE THE SETTLING OF SEDIMENT FROM WATER BEFORE DISCHARGE.
 - OUTLET STABILIZATION**
Practice 6.41
RIPRAP APRONS WILL BE LOCATED AT THE DOWNSTREAM END OF ALL DISCHARGE PIPES TO PREVENT SCOUR.
 - TREE PROTECTION**
Practice 6.05
RESTRICT ACCESS TO TPZ WITH TALL BRIGHT PROTECTIVE FENCING ON AREAS INDICATED ON PLAN.

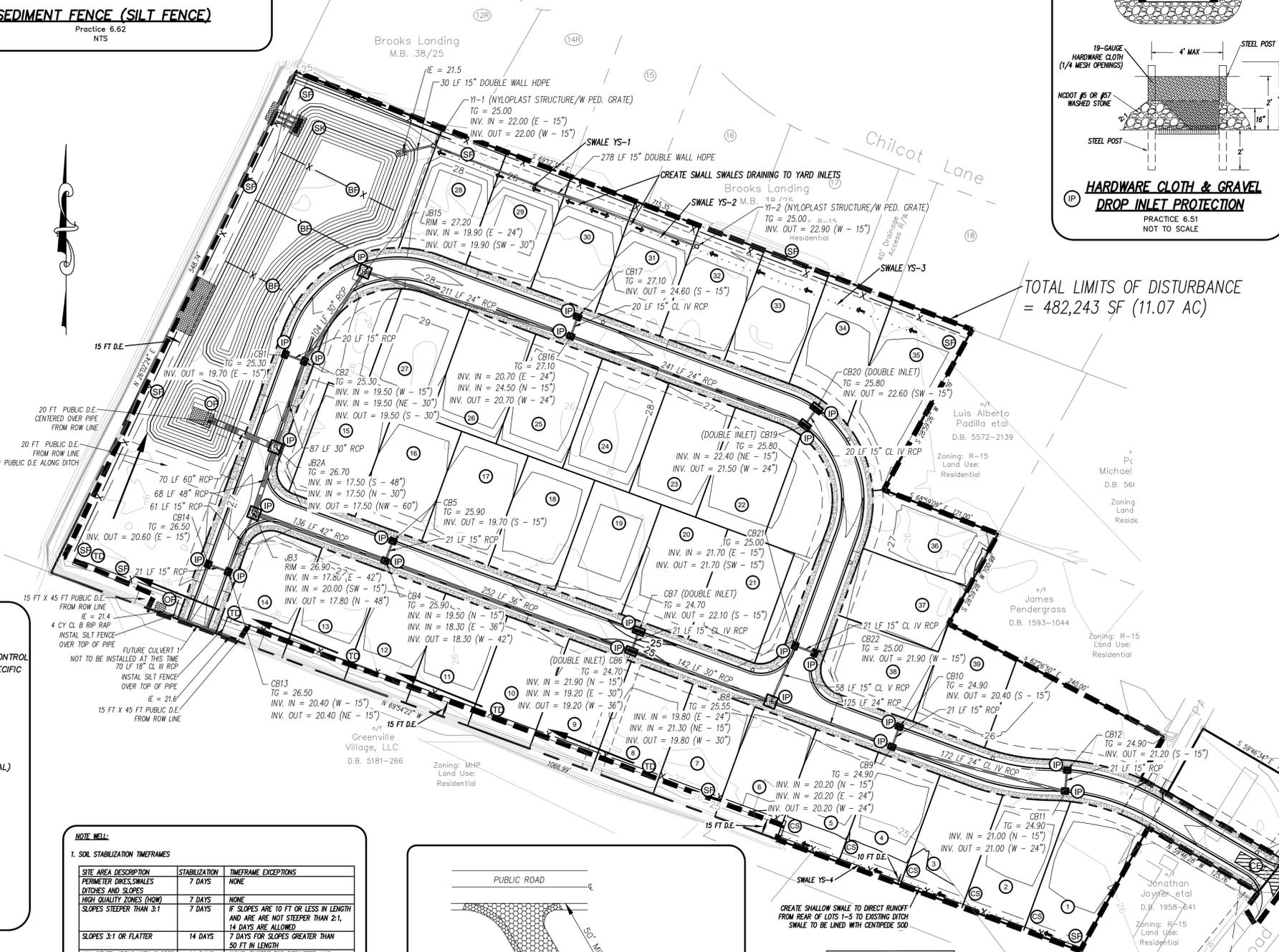

- EROSION CONTROL AND STORMWATER PLAN FOR PACIFIC PLACE**
1. PERMANENT VEGETATION TO BE ESTABLISHED IN ACCORDANCE WITH NORTH CAROLINA EROSION AND SEDIMENT CONTROL PLANNING AND DESIGN MANUAL, SECTION 6.11, LATEST VERSION.

EROSION CONTROL AND STORMWATER PLAN FOR PACIFIC PLACE
LOCATED IN CITY OF WILMINGTON, NORTH CAROLINA
NEW HAMOVER COUNTY, NORTH CAROLINA
OWNER: ARVA HOLDINGS, LLC
P.O. BOX 31722
WILMINGTON, NC 28406

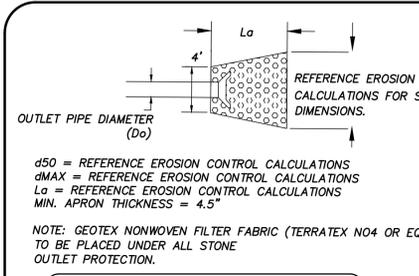

RIP RAP DIMENSIONS

STRUCTURE	L	X	W	X	D	CLASS	QTY
OUTFALL FROM CB1	20'	X	15'	X	1'	II	12 CY
POND OUTFALL	9'	X	10'	X	1'	II	4 CY
CULVERT 1	9'	X	10'	X	1'	II	4 CY
YARD INLET OUTFALL	9'	X	6'	X	1'	II	2 CY

OUTLET PROTECTION DETAIL
NOT TO SCALE

LEGEND

- EXISTING BOUNDARY
- - - LIMITS OF DISTURBANCE
- - - EXISTING CULVERT
- ▨ CONSTRUCTION ENTRANCE
- ⊗ SILT FENCE
- - - PROPOSED CULVERT
- INLET PROTECTION

SITE DATA:
PROPERTY AREA: 488,853 SF or 11.22 AC ±
SOIL TYPE(S):
26,312 SF (0.60 AC) = Le
29,966 SF (0.69 AC) = Lu
353,642 SF (8.12 AC) = Mu

BUILDINGS: 120,000 SF
SIDEWALKS: 21,958 SF
ASPHALT: 49,954 SF
FUTURE: 15,000 SF
TOTAL: 206,932 SF
SQUARE FOOTAGE OF DISTURBANCE: 482,243 SF (11.07 AC)

NOTE: WELL

SITE AREA DESCRIPTION	STABILIZATION	TIMEFRAME EXCEPTIONS
PERIMETER DICES, SWALES, DITCHES AND SLOPES	7 DAYS	NONE
HIGH QUALITY ZONES (HOW)	7 DAYS	NONE
SLOPES STEEPER THAN 3:1	7 DAYS	IF SLOPES ARE 10 FT OR LESS IN LENGTH AND ARE NOT STEEPER THAN 2:1, 14 DAYS ARE ALLOWED.
SLOPES 3:1 OR FLATTER	14 DAYS	7 DAYS FOR SLOPES GREATER THAN 50 FT IN LENGTH.
ALL OTHER AREAS WITH SLOPES FLATTER THAN 4:1	14 DAYS	NONE, EXCEPT FOR PERIMETER AND FLATTER ZONES.

2. DENURED AREAS MUST BE STABILIZED WITHIN FIFTEEN (15) WORKING DAYS OF CEASE OF ANY PHASE OF ACTIVITY. ALL SLOPES MUST BE STABILIZED WITHIN TWENTY-ONE (21) CALENDAR DAYS OF CEASE OF ANY PHASE OF ACTIVITY. THIS INCLUDES SLOPES, SWALES, CHANNELS AND STOCKPILES.
3. THIS PLAN TO BE UTILIZED AND REVIEWED ONLY IN CONJUNCTION WITH THE WRITTEN NARRATIVE, WHICH IS AN INTEGRAL PART OF THIS EROSION AND SEDIMENT CONTROL PLAN.
4. ALL SLOPES SHALL BE 3:1 OR FLATTER.
5. NO WETLANDS EXIST WITHIN LIMITS OF DISTURBANCE.
6. BOUNDARY, TOPOGRAPHIC AND ASBUILT SURVEY PERFORMED BY GEOINNOVATION, PC
7. ELEVATION DATUM: NAVD 88
8. DEVELOPER/HOA ARE RESPONSIBLE FOR MAINTENANCE OF THE STORMWATER SYSTEM.

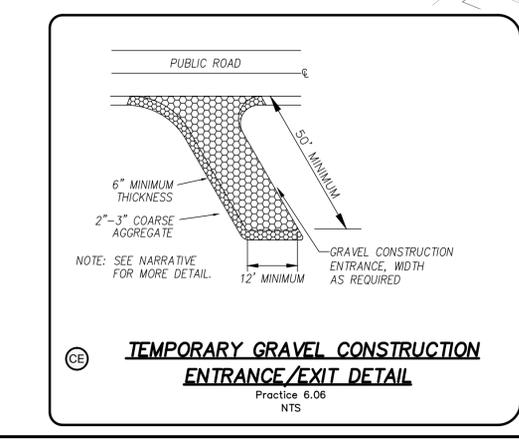

Approved Construction Plan

Name: _____ Date: _____

Planning: _____

Traffic: _____

Fire: _____

CITY OF WILMINGTON
NORTH CAROLINA
Public Services • Engineering Division
APPROVED STORMWATER MANAGEMENT PLAN

Date: _____ Permit # _____

Signed: _____

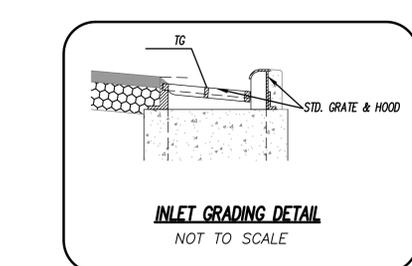

STORMWATER DRAINAGE STRUCTURE NOTES

1. CONTRACTOR AND PRECASTER TO DETERMINE STORM STRUCTURE SIZES.
2. FRAME AND GRATES TO BE MCDOT 840.03
3. RING AND COVERS TO BE MCDOT STD. 840.54
4. STORM STRUCTURES TO BE MCDOT STD. 840.46
5. PRECAST STORM STRUCTURES TO MEET HS-20-44 LOADING.
6. CONTRACTOR TO INSTALL ACCESS COVERS SO THEY ARE NOT LOCATED WITHIN THE CURB AND GUTTER
6. ALL PIPE TO BE CLASS III UNLESS OTHERWISE NOTED.

DATE: 7-18-17
HORZ. SCALE: 1" = 60'
VERT. SCALE: 1" = 6'
DRAWN BY: RLW
CHECKED BY: HSR
PROJECT NO.: 17-0398

Sheet No. **EC1** of **EC3**

SEAL
025483
5-2-19

REV.	DATE	BY	REMARKS
1	5-2-19	MRB	REVISED PER MHC EC COMMENTS
2	7-11-17	RLW	REVISED LOT LAYOUT & NUMBERING, LOD AREA
3	12-11-17	RLW	ADDED PUBLIC DRAINAGE EXHIBITS & COM STIMS
4	10-17-17	RLW	ADDED POND, ADDED DRAIN INLETS & COLLECTION STIMS IN REAR OF LOTS 28-36
5	9-21-17	RLW	ADDED CULVERT 1

For each open utility cut of City streets, a \$325 permit shall be required from the City prior to occupancy and/or project acceptance.

Approved Construction Plan

Name _____ Date _____

Planning _____

Traffic _____

Fire _____

CITY OF WILMINGTON
NORTH CAROLINA

Public Services • Engineering Division

APPROVED STORMWATER MANAGEMENT PLAN

Date: _____ Permit # _____

Signed: _____

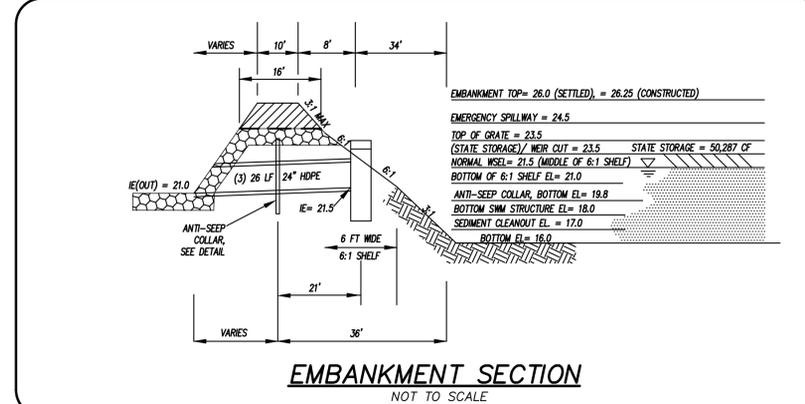
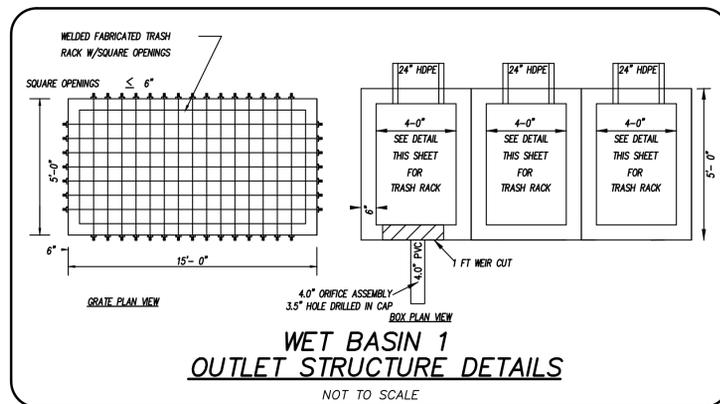
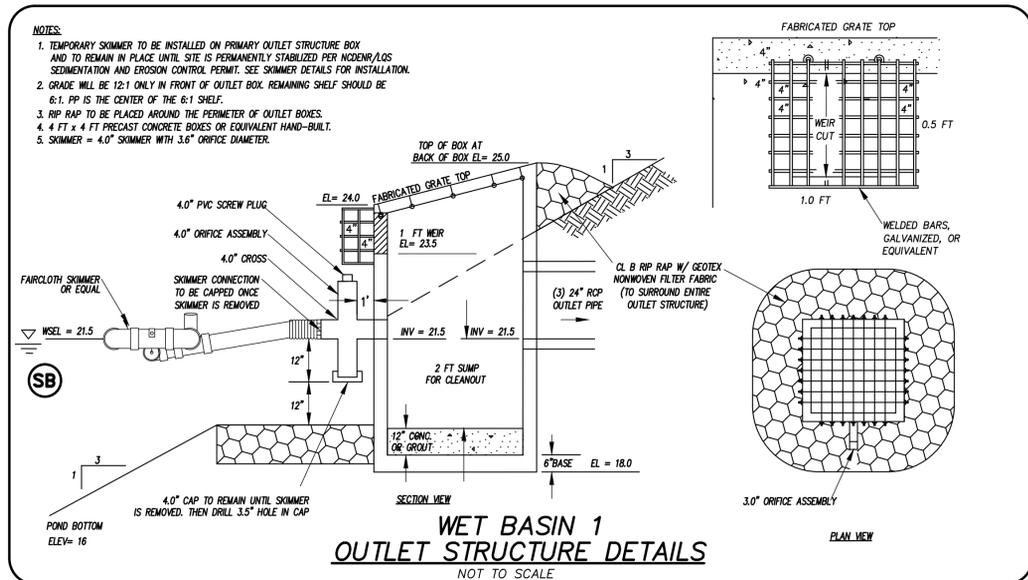
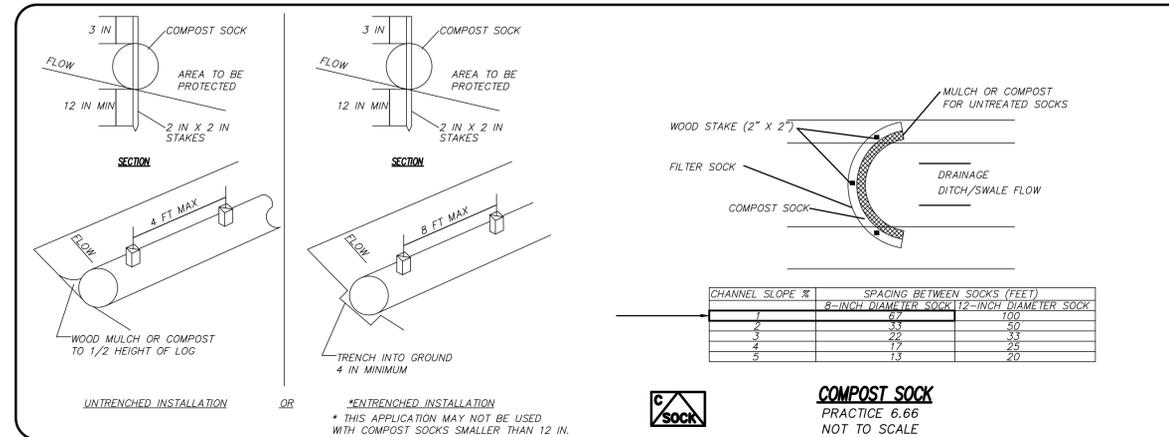
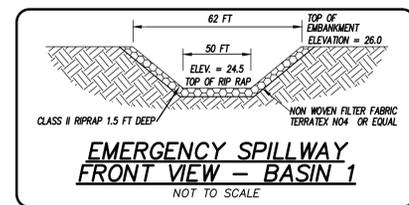
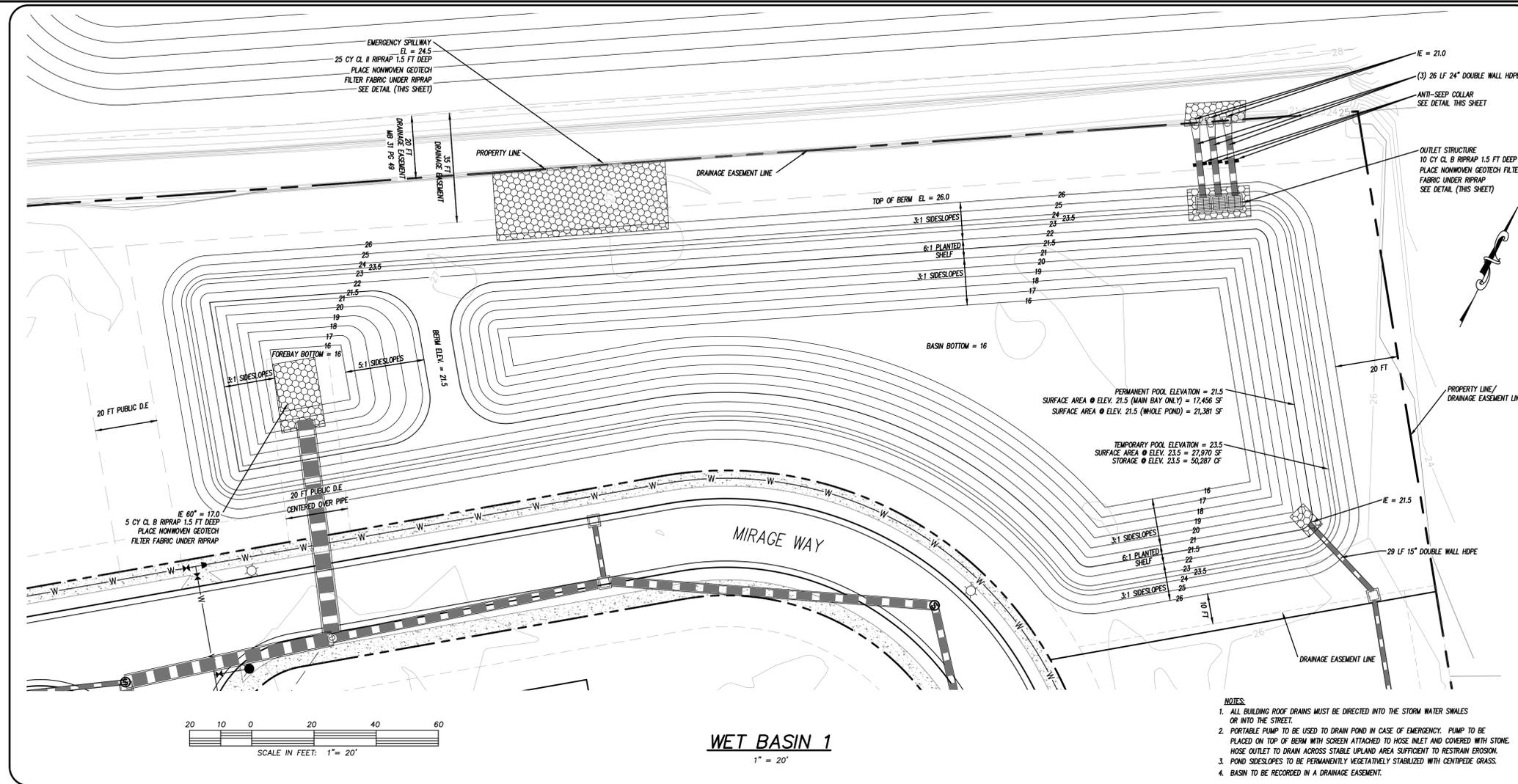
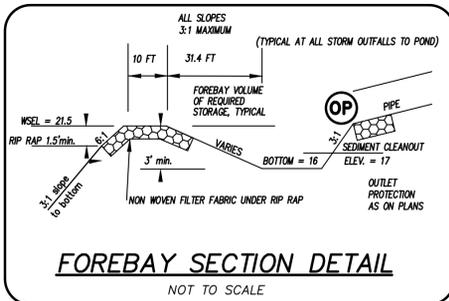

CSD ENGINEERING

LICENSE # C-2710
ENGINEERING
LAND PLANNING
COMMERCIAL / RESIDENTIAL

P.O. BOX 4041
WILMINGTON, NC 28406
(910) 791-4441

POND DETAIL SHEET
PACIFIC PLACE

EROSION CONTROL AND STORMWATER PLAN FOR
PACIFIC PLACE
LOCATED IN CITY OF WILMINGTON, NORTH CAROLINA
NEW HANCOVER COUNTY, NORTH CAROLINA
OWNER: ARYA HOLDINGS, LLC
P.O. BOX 3122
WILMINGTON, NC 28406

SEAL 025483
5-2-19

REVISIONS:

NO.	DATE	BY	REMARKS
1	05-02-19	RLW	REVISED PER I&E COMMENTS
2	05-15-19	RLW	ADDED CALLOUT FOR 15" PIPE ENTERING POND
3	05-15-19	RLW	ADDED FABRIC DRAINAGE EASEMENT & C&W STAMPS
4	05-15-19	RLW	REVISED ROAD NAME, REISED POND

DATE: 7-18-17

HORIZ. SCALE: 1" = 10'

VERT. SCALE: N/A

DRAWN BY: RLW

CHECKED BY: HSR

PROJECT NO.: 17-0398

Sheet No. **EC2** of **EC3**

Construction Road Stabilization
Specification # 6.80 - Construction Specifications

1. Clear roadbed and parking areas of all vegetation, roots and other objectionable material.
2. Ensure that road construction follows the natural contours of the terrain if it is possible.
3. Locate parking areas on naturally flat areas if they are available. Keep grades sufficient for drainage but generally not more than 2 to 3%.
4. Provide surface drainage and divert excess runoff to stable areas by using water bars or turnouts (References: Runoff Control Measures).
5. Keep cuts and fills at 2:1 or flatter for safety and stability and to facilitate establishment of vegetation and maintenance.
6. Spread a 6-inch course of "ABC" crushed stone evenly over the full width of the road and smooth to avoid depressions.
7. Where seepage areas or seasonally wet areas must be crossed, install subsurface drains or geotextile fabric cloth before placing the crushed stone (Practice 6.81, Subsurface Drain).
8. Vegetate all roadside ditches, cuts, fills and other disturbed areas or otherwise appropriately stabilize as soon as grading is complete (References: Surface Stabilization).
9. Provide appropriate sediment control measures to prevent off-site sedimentation.

Maintenance
Inspect construction roads and parking areas periodically for condition of surface. Topdresses with new gravel as needed. Check road ditches and other seeded areas for erosion and sedimentation after runoff-producing rains. Maintain all vegetation in a healthy, vigorous condition. Sediment-producing areas should be treated immediately.

Temporary Gravel Construction Entrance/Exit
Specification # 6.06 - Construction Specifications

1. Clear the entrance and exit area of all vegetation, roots and other objectionable material and properly grade it.
2. Place the gravel to the specific grade and dimensions shown on the plans and smooth it.
3. Provide drainage to carry water to a sediment trap or other suitable outlet.
4. Use geotextile fabrics because they improve stability of the foundation in locations subject to seepage or high water table.

Maintenance
Maintain the gravel pad in a condition to prevent mud or sediment from leaving the construction site. This may require periodic topdressing with 2-inch stone. After each rainfall, inspect any structure used to trap sediment and clean it out as necessary. Immediately remove all objectionable material spilled, washed, or tracked onto public roadways.

Temporary Seeding
Specification # 6.10 - Specifications

Complete grading before preparing seedbeds and install all necessary erosion control practices, such as dikes, waterways and basins. Minimize steep slopes because they make seedbed preparation difficult and increase the erosion hazard. If soils become compacted during grading, loosen them to a depth of 6-8 inches using a ripper, harrow, or chisel plow.

Seedbed Preparation
Good seedbed preparation is essential to successful plant establishment. A good seedbed is well-pulverized, loose and uniform. Where hydroseeding methods are used, the surface may be left with a more irregular surface of large clods and stones.

Liming - Apply lime according to soil test recommendations. If the pH (activity) of the soil is not known, an application of ground agricultural limestone of the rate of 1 to 1 1/2 tons/acre on coarse-textured soils and 2-3 tons/acre on fine-textured soils is usually sufficient. Apply limestone uniformly and incorporate into the top 4-6 inches of soil. Soils with a pH of 6 or higher need not be limed.

Fertilizer - Base application rates on soil tests. When these are not possible, apply a 10-10-10 grade fertilizer at 700-1000 lb/acre. Both fertilizer and lime should be incorporated into the top 4-6 inches of soil. If a hydraulic seeder is used, do not mix seed and fertilizer more than 30 minutes before application.

Surface roughening - If recent tillage operations have resulted in a loose surface, additional roughening may be required except to break up large clods. If rainfall causes the surface to become sealed or crusted, loosen it just prior to seeding by disking, raking, harrowing, or other suitable methods. Grooves or furrows slope steeper than 3:1 on the contour before seeding (Practice 6.03, Surface Roughening).

Plant Selection
Select on appropriate species or species mixture from Table 6.10a, for seeding in late winter and early spring, Table 6.10b, for summer, and Table 6.10c, for fall.

Seeding
Evenly apply seed using a cyclone seeder (broadcast), drill, cultipacker seeder, or hydroseeder. Use seeding rates given in Table 6.10a-6.10c. Broadcast seeding and hydroseeding are appropriate for steep slopes where equipment cannot be driven. Hand broadcasting is not recommended because of the difficulty in achieving a uniform distribution. Small grasses should be planted no more than 1 inch deep, and grasses and legumes no more than 1/2 inch. Broadcast seed must be covered by raking or chain dragging, and then lightly firm with a roller or cultipacker. Hydroseeded mixtures should include a wood fiber (cellulose) mulch.

Mulching
The use of appropriate mulch will help ensure establishment under normal conditions and is essential to seeding success under harsh site condition (Practice 6.14, Mulching). Harsh site conditions include:
- seeding in fall for winter cover (wood fiber mulches are not considered adequate for this use),
- slopes steeper than 3:1,
- excessively hot or dry weather,
- adverse soil/shallow, rocky, or high in clay or sand, and
- areas receiving concentrated flow.

If the area to be mulched is subject to concentrated waterflow, as in channels, anchor mulch with netting (Practice 6.14, Mulching).

Table 6.11v - Seeding No. 70P for Grass-lined Channels, Coastal Plain
Seeding Mixture
Species - Common Bermudagrass - Rate - 40-80 (1/2 lb/1,000 ft.)
Seeding dates - Coastal Plain: Apr - July
Soil amendments - Apply lime and fertilizer according to soil tests, or apply 3,000 lb/acre ground agricultural limestone and 500 lb/acre 10-10-10 fertilizer.

Mulch - Use lime, excelsior matting, or other effective channel lining material to cover the bottom of channels and ditches. The lining should extend above the highest calculated depth of flow. On channel side slopes above the height, and in drainage not requiring temporary linings, apply 4,000 lb/acre grain straw and anchor straw by stapling netting over the top.

Mulch and anchoring materials must be allowed to wash down slopes where they can clog drainage devices.

Maintenance - A minimum of 3 weeks is required for establishment. Inspect and repair mulch frequently. Refertilize the following Apr. with 50 lb/acre.

Refer to Appendix 6.02 for botanical names

Permanent Seeding
Specifications # 6.11 - Specifications

Seedbed Requirements
Establishment of vegetation should not be attempted on sites that are unsuitable due to inappropriate soil texture (Table 6.11a), poor drainage, concentrated overland flow, or steepness of slope until measures have been taken to correct these problems.

To maintain a good stand of vegetation, the soil must meet certain minimum requirements as a growth medium. The existing soil should have these criteria:
- Enough fine-grained (silt and clay) material to maintain adequate moisture and nutrient supply (available water capacity of at least .05 inches water to 1 inch of soil).
- Sufficient pore space to permit root penetration.
- Sufficient depth of soil to provide an adequate root zone. The depth to rock or impermeable layers such as hardpan should be 12 inches or more, except on slopes steeper than 2:1 where the addition of soil is not feasible.
- A favorable pH range for plant growth, usually 6.0-6.5.
- Freedom from large roots, branches, stones, large clods of earth, or trash of any kind. Clods and stones may be left on slopes steeper than 3:1 if they are to be hydroseeded.

If any of the above criteria are not met--i.e., if the existing soil is too coarse, dense, shallow or acidic to foster vegetation-specific amendments are required. The soil conditions described below may be beneficial or, preferably, topsoil may be applied in accordance with Practice 6.04, Topsoiling. Soil Conditions
In order to improve the structure or drainage characteristics of a soil, the following material may be added. These amendments should only be necessary where soils have limitations that make them poor for plant growth or for fine turf establishment (see Chapter 3, Vegetative Considerations).

Peat-Appropriate types are sphagnum moss peat, hudson moss peat, reedbed peat, or peat humus, all from fresh-water sources. Peat should be stored and conditioned in storage piles for at least 6 months after excavation.

Sand-clean and free of toxic materials. Vermiculite-horticultural grade and free of toxic substances.

Rotted manure-stable or cattle manure not containing undue amounts of straw or other bedding materials.

Thoroughly rotted sawdust-free of stones and debris. Add 6 lb. Of nitrogen to each cubic yard.

Sludge-Treated sewage and industrial sludges are available in various forms; these should be used only in accordance with local, State and Federal regulations.

Species Selection
Use the key to Permanent Seeding Mixtures (Table 6.11b) to select the most appropriate seeding mixture based on the general site and maintenance factors. A listing of species, including scientific names and characteristics, is given in Appendix 6.02.

Soil Preparation
Install necessary mechanical erosion and sedimentation control practices before seeding, and complete grading according to the approved plan.

Lime and fertilizer needs should be determined by soil tests. Soil testing is performed free of charge by the North Carolina Department of Agriculture soil testing laboratory. Directions, sample cartons, and information sheets are available through county agricultural extension offices or from NCDA. Because the NCDA soil testing lab requires 1-6 weeks for sample turn-around, sampling must be planned well in advance of final grading. Testing is also done by commercial laboratories.

When soil test are not available, follow rates suggested on the individual specification sheet for the seeding mix chosen (Tables 6.11c through 6.11v).

Applications rates usually fall into the following ranges:
- Ground agricultural limestone
- Light-textured, sandy soils: 1-1 1/2 tons/acre
- Heavy textured, clayey soils 2-3 tons/acre
- Fertilizer:
- Grasses 800-1200 lb/acre of 10-10-10 (or the equivalent)
- Grass-legume mixtures: 800-1200 lb/acre of 5-10-10 (or the equivalent)

Apply lime and fertilizer evenly and incorporate into the top 4-6 inches of soil by disking or other suitable means. Operate machinery on the contour. When using a hydroseeder, apply lime and fertilizer to a rough, loose surface.

Roughen surfaces according to Practice 6.03, Surface Roughening. Complete seedbed preparation by breaking up large clods and raking into a smooth, uniform surface (slope less than 3:1) Fill in or level depressions that can collect water. Broadcast seed into a freshly loosened seedbed that has not been seeded by rainfall.

Table 6.11a - Seeding No. 40P for Well-Drained Sandy Soils to Dry Sands, Coastal Plain; Low to Medium-Care Lawns
Seeding Mixture
Species - Ryegrass
Seeding dates - Apr. 15 - Aug. 15
Soil amendments - Follow recommendations of soil tests or apply 2,000 lb/acre ground agricultural limestone and 750 lb/acre 10-10-10 fertilizer.

Mulch - Apply 4,000 lb/acre straw. Anchor straw by tacking with asphalt, netting, or a mulch anchoring tool. A disk with blades set nearly straight can be used as a mulch anchoring tool.

Maintenance - Refertilize if growth is not fully adequate. Reseed, refertilize and mulch immediately following erosion or other damage.

Table 6.10c - Temporary Seeding Recommendation for Fall
Seeding Mixture
Species - Ryegrass
Seeding dates - Coastal Plain and Piedmont - Aug 15 - Dec. 30
Soil amendments - Follow soil tests or apply 2,000 lb/acre ground agricultural limestone and 1,000 lb/acre 10-10-10 fertilizer.

Mulch - Apply 4,000 lb/acre straw. Anchor straw by tacking with asphalt, netting, or a mulch anchoring tool. A disk with blades set nearly straight can be used as a mulch anchoring tool.

Maintenance - Repair and refertilize damaged areas immediately. Topdress with 50 lb/acre of nitrogen in March, if it is necessary to extend temporary cover beyond June 15, overseed with 50 lb/acre Koba (Piedmont and Coastal Plain)

Table 6.11b - Seeding No. 50P for Well-Drained Sandy Soils to Dry Sands; Low Seeding Mixture
Species Rate (lb/acre)
Panicum Bahiagrass 50
Sericea lespedeza 30
Common bermudagrass 10
German millet 10

Seeding notes
1. Where a neat appearance is desired, omit sericea.
2. Use common Bermudagrass only on isolated sites where it cannot become a pest. Bermudagrass may be replaced with 5 lb/acre centipedegrass.

Seeding dates - Apr. 1 - July 15
Soil amendments - Apply lime and fertilizer according to soil tests, or apply 3,000 lb/acre ground agricultural limestone and 500 lb/acre 10-10-10 fertilizer.

Mulch - Use lime, excelsior matting, or other effective channel lining material to cover the bottom of channels and ditches. The lining should extend above the highest calculated depth of flow. On channel side slopes above the height, and in drainage not requiring temporary linings, apply 4,000 lb/acre grain straw and anchor straw by stapling netting over the top.

Mulch and anchoring materials must be allowed to wash down slopes where they can clog drainage devices.

Maintenance - A minimum of 3 weeks is required for establishment. Inspect and repair mulch frequently. Refertilize the following Apr. with 50 lb/acre.

Refer to Appendix 6.02 for botanical names

Land Grading
Specification # 6.02 - Construction Specifications

1. Construct and maintain all erosion and sedimentation control practices and measures in accordance with the approved sedimentation control plan and construction schedule.

2. Remove good topsoil from areas to be graded and filled, and preserve it for use in finishing the grade of all critical areas.

3. Scarify areas to be topsoiled to a minimum depth of 2 inches before placing topsoil (Practice 6.04, Topsoiling).

4. Clear and grub areas to be filled to remove trees, vegetation, roots, or other objectionable material that would affect the planned stability of the fill.

5. Ensure that fill material is free of brush, rubbish, rocks, logs, stumps, building debris, and other materials inappropriate for constructing stable fills.

6. Place all fill in layers not to exceed 9 inches in thickness, and compact the layers as required to reduce erosion, slippage, settlement, or other related problems.

7. Do not incorporate frozen material or soft, mucky, or highly compressible materials into fill slopes.

8. Do not place fill on a frozen foundation, due to possible subsidence and slippage.

9. Keep diversions and other water conveyance measures free of sediment during all phases of development.

10. Handle seeps or springs encountered during construction in accordance with approved methods (Practice 6.81, Subsurface Drain).

11. Permanently stabilize all graded areas immediately after final grading is completed on each area in the grading plan. Apply temporary stabilization measures on all graded areas when work is to be interrupted or delayed for 30 working days or longer.

12. Ensure that topsoil stockpiles, borrow areas, and spoil areas are adequately protected from erosion with temporary and final stabilization measures, including sediment fencing and temporary seeding as necessary.

Maintenance
Periodically check all graded areas and the supporting erosion and sedimentation control practices, especially after heavy rainfalls. Promptly remove all sediment from diversions and other water-disposal practices. If weabouts or breaks occur, repair them immediately. Prompt maintenance of small eroded areas before they become significant gullies is an essential part of an effective erosion and sedimentation control plan.

Temporary Seeding (continued)

Table 6.10a - Temporary Seeding Recommendation for Late Winter and Early Spring
Seeding Mixture
Species - Ryegrass, Annual lespedeza (Koba in Piedmont and Coastal Plain Rate (lb/acre) - 120
Omit annual lespedeza when duration of temporary cover is not to extend beyond June

Seeding dates - Coastal Plain - Dec. 1 - Apr. 15
Soil amendments - Follow recommendations of soil tests or apply 2,000 lb/acre ground agricultural limestone and 750 lb/acre 10-10-10 fertilizer.

Mulch - Apply 4,000 lb/acre straw. Anchor straw by tacking with asphalt, netting, or a mulch anchoring tool. A disk with blades set nearly straight can be used as a mulch anchoring tool.

Maintenance - Refertilize if growth is not fully adequate. Reseed, refertilize and mulch immediately following erosion or other damage.

Table 6.10b - Temporary Seeding Recommendations for Summer
Seeding Mixture
Species - German millet
Rate (lb/acre) - 40
Seeding dates - Coastal Plain - Apr. 15 - Aug. 15
Soil amendments - Follow recommendations of soil tests or apply 2,000 lb/acre ground agricultural limestone and 750 lb/acre 10-10-10 fertilizer.

Mulch - Apply 4,000 lb/acre straw. Anchor straw by tacking with asphalt, netting, or a mulch anchoring tool. A disk with blades set nearly straight can be used as a mulch anchoring tool.

Maintenance - Repair and refertilize damaged areas immediately. Topdress with 50 lb/acre of nitrogen in March, if it is necessary to extend temporary cover beyond June 15, overseed with 50 lb/acre Koba (Piedmont and Coastal Plain)

Outlet Stabilization Structure
Specification # 6.41 - Construction Specifications

1. Ensure that the subgrade for the filter and riprap follows the required lines and grades shown in the plan. Compact any fill required in the subgrade to the density of the surrounding undisturbed material. Low areas in the subgrade on undisturbed soil may also be filled by increasing the riprap thickness.

2. The riprap and gravel filter must conform to the specified grading limits shown on the plans.

3. Filter cloth, when used, must meet design requirements and be properly protected from punching or tearing during installation. Repair any damage by removing the riprap and patching another piece of filter cloth over the damaged area. All connecting joints should overlap a minimum of 1 ft. If the damage is extensive, replace the entire filter cloth.

4. Riprap may be placed by equipment, but take care to avoid damaging the filter.

5. The minimum thickness of the riprap should be 1.5 times the maximum stone diameter.

6. Riprap may be field stone or rough quarry stone. It should be hard, angular, highly weather-resistant and well graded.

7. Construct the apron on zero grade with no overfall at the end. Make the top of the riprap at the downstream level with the receiving area or slightly below it.

8. Ensure that the apron is properly aligned with the receiving stream and preferably straight throughout its length. If a curve is needed to fit site conditions, place it in the upper section of the apron.

9. Immediately after construction, stabilize all disturbed areas with vegetation (Practice 6.10, Temporary Seeding, and 6.11, Permanent Seeding).

Maintenance
Inspect riprap outlet structures after heavy rains to see if any erosion around or below the riprap has taken place or if stones have been dislodged. Immediately make all needed repairs to prevent further damage.

(SF)

Sediment Fence (Silt Fence)
Specification 6.62 - Construction Specifications

MATERIALS
1. Use a synthetic filter fabric or a porous sheet of polypropylene, nylon, polyester, or polyethylene yarn, which is certified by the manufacturer or supplier as conforming to the requirements shown in Table 6.62a. Synthetic filter fabric should contain ultraviolet ray inhibitors and stabilizers to provide a minimum of 6 months of expected usable construction life at a temperature range of 10 to 120 F.

2. Ensure that posts for sediment fences are 1.33 lb/linear ft steel with a minimum length of 4 ft. Make sure that steel post have projects to facilitate fastening the fabric.

3. For reinforcement of standard strength filter fabric, use wire fence with a minimum 14 gauge and a maximum mesh spacing of 6 inches.

Table 6.62b
Specifications for Sediment Fence Fabric
Physical Property Requirements
Filtering Efficiency - 85% (min)
Tensile Strength of Standard Strength - 30 lb/in (min)
Extra Strength - 50 lb/in (min)
Slurry Flow Rate - 0.3 gal/sq ft/min (min)

CONSTRUCTION
1. Construct the sediment barrier of standard strength or extra strength synthetic filter fabric.

2. Ensure that the height of the sediment fence does not exceed 18 inches above the ground surface. (Higher fences may impound volumes of water sufficient to cause failure of the structure.)

3. Construct the filter fabric from a continuous roll out to the length of the barrier in avoid joints. When joints are necessary, securely fasten the filter cloth only at a support post with overlap to the next post.

4. Support standard strength filter fabric by wire mesh fastened securely to the up slope side of the posts using heavy duty wire staples at least 1 inch long, or tie wires. Extend the wire mesh support to the bottom of the trench.

5. When a wire mesh support fence is used, space posts a maximum of 8 ft apart. Support posts should be driven securely into the ground to a minimum of 18 inches.

6. Extra strength filter fabric with 6ft post spacing does not require wire mesh support fence. Staple or wire the filter fabric directly to posts.

7. Excavate a trench approximately 4 inches wide and 8 inches deep along the proposed line of posts and upslope from the barrier (figure 6.62a).

8. Backfill the trench with compacted soil or gravel placed over the filter fabric.

9. Do not attach filter fabric to existing trees.

Maintenance
Inspect sediment fences at least once a week and after each rainfall. Make any required repairs immediately.

Should the fabric of a sediment fence collapse, tear, decompose or become ineffective, replace it promptly. Replace backup every 60 days.

Remove sediment deposits as necessary to provide adequate storage volume for the next rain and to reduce pressure on the fence. Take care to avoid undermining the fence during cleanout.

Remove all fencing materials and unstable sediment deposits and bring the area to grade and stabilize it after the contributing drainage area has been properly stabilized.

(SK)

Skimmer Sediment Basin
Specification 6.64.7 - Construction Specifications

MATERIALS
1. Clear, grub and strip the area under the embankment of all vegetation and root stock. Remove all surface soil containing high amounts of organic matter or sludge or debris of any kind. Operate machinery on the contour. In the designated disposal area, place temporary sediment control measures below basins as needed.

2. Ensure that fill material for the embankment is free of roots, woody vegetation, organic matter, and other objectionable material. Place the fill in layers not to exceed 9 inches in thickness, and compact it under and around the basin to allow for settlement.

3. Shape the basin to the specified dimensions. Prevent the skimming device from getting into the mud by constructing a shoulder all under the skimmer or providing a low support under the skimmer of stone or timber.

4. Place the bars (typically 4-inch Schedule 40 PVC pipe) on a firm, smooth foundation of limestone or concrete. Do not use wooden planks, logs, steel gravel, or crushed stone as backfill around the pipe. Place the fill material around the pipe in layers not to exceed 9 inches in thickness. Compact the fill to the pipe to at least the same density as the adjacent embankment. Care must be taken not to raise the pipe from the firm contact with its foundation when compacting under the pipe flaunches.

5. Assemble the skimmer following the manufacturer's instructions, or as designed.

6. Lay the assembled skimmer on the bottom of the basin with the flexible part of the inlet of the barrel pipe. Attach the flexible part to the barrel pipe with the skimmer assembly. The skimmer should be placed on the pipe so that a rope to the skimmer and anchor to the side of the basin. The rope will be used to pull the skimmer to the side for maintenance.

7. Earthen embankment of the skimmer is undisturbed soil to the greatest extent possible. The embankment of the skimmer should be graded, sloped, and anchored with chain link wire or similar to the approved operation of the skimmer. The skimmer should be placed on the pipe so that a rope to the skimmer and anchor to the side of the basin. The rope will be used to pull the skimmer to the side for maintenance.

8. Inlet-Discharge water into the basin in a manner to prevent erosion. Use temporary slope drains or diversions with outlet protection to divert sediment-laden water to the upper end of the post area to improve basin top efficiency.

9. Erosion control-Construct the structure so that the disturbed area is minimized. Level surface water away from basins. Complete the embankment before the area is graded. Stabilize the embankment with vegetation, erosion control fabric, or other suitable material. Stabilize the embankment with vegetation, erosion control fabric, or other suitable material. Stabilize the embankment with vegetation, erosion control fabric, or other suitable material.

10. After all the sediment-producing areas have been permanently stabilized, remove the structure and all the unstable sediment embankment area to blend with the adjoining areas and stabilize properly (References: Surface Stabilization).

Inspect skimmer sediment basins at least weekly and after each significant (one-half inch or greater) rainfall event and repair immediately. Remove sediment from the basin at least once a week. The skimmer should be placed on the pipe so that a rope to the skimmer and anchor to the side of the basin. The rope will be used to pull the skimmer to the side for maintenance.

Check the fabric lined spillway for damage and make any required repairs with fabric that spans the full width of the spillway. Check the embankment, spillway, and outlet for erosion damage, and inspect the embankment for piping and settlement. Make all necessary repairs immediately. Remove all sediment and other debris from the skimmer and pool areas.

Freezing weather can result in ice forming in the basin. Some special precautions should be taken in the winter to prevent the skimmer from plugging with ice.

(IP)

HARDWARE CLOTH & GRAVEL INLET PROTECTION
Specification # 6.51 - Construction Specifications

1. Uniformly grade a shallow depression approaching the inlet.
2. Drive 5 FT steel post 2 FT into the ground surrounding the inlet.
Space post evenly around the perimeter of the inlet, a maximum of 4 FT apart.

3. Surround the posts with wire mesh hardware cloth. Secure the wire mesh to steel posts at the top, middle, and bottom. Placing a 2 FT flap of the wire mesh under the gravel for anchoring is recommended.

4. Place clean gravel (NC DOT #5 or #57 stone) on a 2:1 slope with a height of 16 inches around the wire, and smooth to an even grade.

5. Once the contributing drainage area has been stabilized, remove accumulated sediment, and establish final grading elevations.

6. Compact the area properly and stabilize it with ground cover.

Maintenance
Inspect inlets at least weekly and after each significant (0.5 in or greater) rainfall event. Clear the mesh wire of any debris or other objects to provide adequate flow for subsequent rains. Take care not to damage or undercut the wire mesh during sediment removal. Replace stone as needed.

Approved Construction Plan
Name _____ Date _____
Planning _____
Traffic _____
Fire _____

WILMINGTON
NORTH CAROLINA
Public Services • Engineering Division
APPROVED STORMWATER MANAGEMENT PLAN
Date: _____ Permit # _____
Signed: _____

For each open utility cut of City streets, a \$325 permit shall be required from the City prior to occupancy and/or project acceptance.

Table 6.62a
Specifications for Sediment Fence Fabric
Physical Property Requirements
Filtering Efficiency - 85% (min)
Tensile Strength of Standard Strength - 30 lb/in (min)
Extra Strength - 50 lb/in (min)
Slurry Flow Rate - 0.3 gal/sq ft/min (min)

CONSTRUCTION
1. Construct the sediment barrier of standard strength or extra strength synthetic filter fabric.

2. Ensure that the height of the sediment fence does not exceed 18 inches above the ground surface. (Higher fences may impound volumes of water sufficient to cause failure of the structure.)

3. Construct the filter fabric from a continuous roll out to the length of the barrier in avoid joints. When joints are necessary, securely fasten the filter cloth only at a support post with overlap to the next post.

4. Support standard strength filter fabric by wire mesh fastened securely to the up slope side of the posts using heavy duty wire staples at least 1 inch long, or tie wires. Extend the wire mesh support to the bottom of the trench.

5. When a wire mesh support fence is used, space posts a maximum of 8 ft apart. Support posts should be driven securely into the ground to a minimum of 18 inches.

6. Extra strength filter fabric with 6ft post spacing does not require wire mesh support fence. Staple or wire the filter fabric directly to posts.

7. Excavate a trench approximately 4 inches wide and 8 inches deep along the proposed line of posts and upslope from the barrier (figure 6.62a).

8. Backfill the trench with compacted soil or gravel placed over the filter fabric.

9. Do not attach filter fabric to existing trees.

Maintenance
Inspect sediment fences at least once a week and after each rainfall. Make any required repairs immediately.

Should the fabric of a sediment fence collapse, tear, decompose or become ineffective, replace it promptly. Replace backup every 60 days.

Remove sediment deposits as necessary to provide adequate storage volume

For each open utility cut of City streets, a \$325 permit shall be required from the City prior to occupancy and/or project acceptance.

Approved Construction Plan

Name _____ Date _____

Planning _____

Traffic _____

Fire _____

CITY OF WILMINGTON
NORTH CAROLINA

Public Services • Engineering Division

APPROVED STORMWATER MANAGEMENT PLAN

Date: _____ Permit # _____

Signed: _____

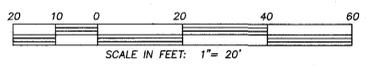
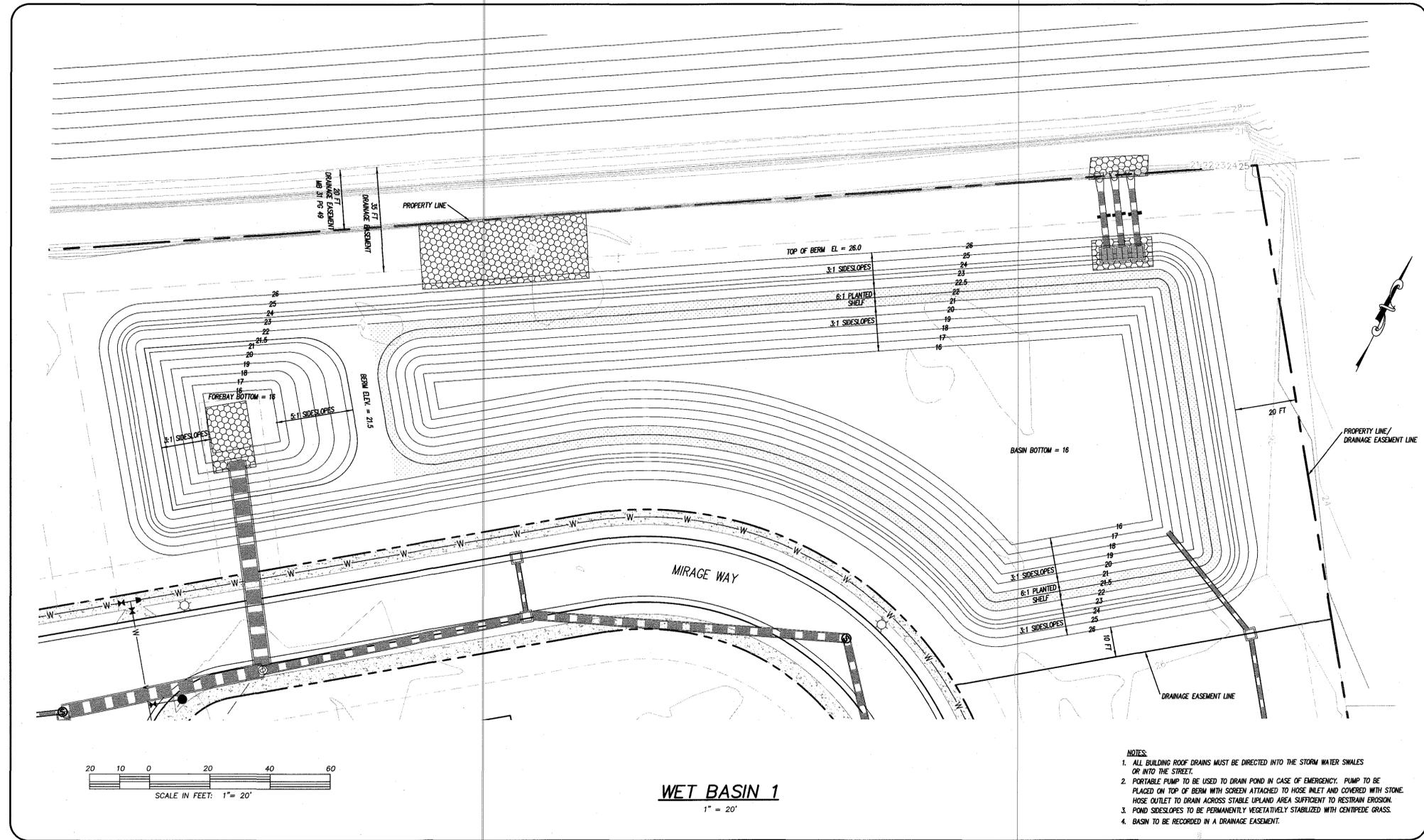

WET BASIN 1
1" = 20'

- NOTES:**
1. ALL BUILDING ROOF DRAINS MUST BE DIRECTED INTO THE STORM WATER SWALES OR INTO THE STREET.
 2. PORTABLE PUMP TO BE USED TO DRAIN POND IN CASE OF EMERGENCY. PUMP TO BE PLACED ON TOP OF BERM WITH SCREEN ATTACHED TO HOSE INLET AND COVERED WITH STONE. HOSE OUTLET TO DRAIN ACROSS STABLE UPLAND AREA SUFFICIENT TO RESTRAIN EROSION.
 3. POND SIDESLOPES TO BE PERMANENTLY VEGETATIVELY STABILIZED WITH CENTIPEDE GRASS.
 4. BASIN TO BE RECORDED IN A DRAINAGE EASEMENT.

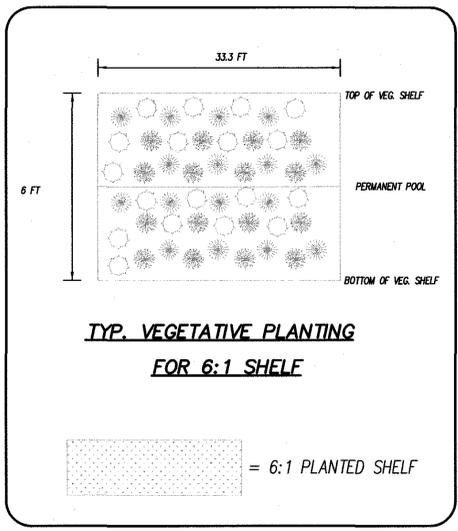

Proposed Plant Table

VEGETATIVE PLANTING 6:1 SHELF

Quantity	Symbol	Scientific Name	Common Name	Planting Size	Planting Remarks	Planting Season
340	(Symbol)	EUPATORIADALPHUS FISTULOSUS	JOE PYE WEED	4 CUBIC INCH	8" O.C.	SPRING, FALL
340	(Symbol)	ASCLEPIAS INCARNATA	SWAMP MILKWEED	4 CUBIC INCH	8" O.C.	SPRING, FALL
340	(Symbol)	CAREX TENERA	QUILL SEDGE	4 CUBIC INCH	8" O.C.	SPRING, FALL

O.C. - "ON CENTER" CAL. - "CALIPER AT 6" ABOVE GRADE" GAL. - "GALLON CONTAINER"

PLANTINGS REQUIRED = 4,086 SF / 200 = 20.4 X 50 = 1,020 PLANTS REQUIRED
MINIMUM OF 3 DIFFERENT SPECIES REQUIRED

REMAINING PORTION OF POND ABOVE 6:1 SHELF TO BE PLANTED WITH CENTIPEDE GRASS.
FOREBAY BERM TO BE CENTIPEDE GRASS OR LINED WITH RIP RAP

PLANTINGS NOTES:

1. WORK SHALL MEET THE REQUIREMENTS OF ALL LOCAL, STATE, AND FEDERAL GOVERNING CODES, ORDINANCES, LAWS, REGULATIONS, SAFETY ORDERS AND DIRECTIVES.
2. CONTRACTOR SHALL BE RESPONSIBLE FOR MAKING HIMSELF/HERSELF FAMILIAR WITH ALL UNDERGROUND UTILITIES, PIPES AND STRUCTURES. CONTRACTOR SHALL TAKE SOLE RESPONSIBILITY FOR ANY COST INCURRED DUE TO DAMAGE OF SAID UTILITIES.
3. CONTRACTOR MUST CHECK ALL SITE CONDITIONS PRIOR TO COMMENCING WORK. CONTRACTOR SHALL NOT WILLFULLY PROCEED WITH CONSTRUCTION AS DESIGNED WHEN IT IS OBVIOUS THAT UNKNOWN OBSTRUCTIONS AND/OR GRADE DIFFERENCES EXIST THAT MAY NOT HAVE BEEN KNOWN DURING DESIGN. SUCH CONDITIONS SHALL BE IMMEDIATELY BROUGHT TO THE ATTENTION OF THE ENGINEER. THE CONTRACTOR SHALL ASSUME FULL RESPONSIBILITY FOR ALL NECESSARY REVISIONS DUE TO FAILURE TO GIVE SUCH NOTIFICATION.
4. ALL PLANT QUANTITIES ARE IDENTIFIED BY TYPICAL SYMBOLS. REFER TO PLANT LEGEND FOR QUANTITIES. PLANT QUANTITIES ARE APPROXIMATE AND ARE PROVIDED FOR THE CONVENIENCE OF THE CONTRACTOR. IT SHALL BE THE CONTRACTOR'S RESPONSIBILITY TO CONFIRM ALL PLANT QUANTITIES PRIOR TO BIDDING. IN THE EVENT OF DISCREPANCIES IN PLANT COUNT, QUANTITIES INDICATED BY PLANT SYMBOLS SHALL PREVAIL.
5. CONTRACTOR SHALL NOTIFY DESIGNER IF ANY SPECIFIED PLANT MATERIAL IS FOUND TO BE UNAVAILABLE.
6. ALL AREAS NOT WITHIN THE 6:1 SHELF SHALL BE STABILIZED WITH CENTIPEDE GRASS
7. IF ANY OF SPECIFIED PLANTS ARE UNAVAILABLE, CHOOSE A NATIVE ALTERNATIVE FROM LIST ON THIS PAGE.

PLANTINGS FOR 6:1 VEGETATIVE SHELF

- ASCLEPIAS INCARNATA (SWAMP MILKWEED)
- CAREX TENERA (QUILL SEDGE)
- CHELONE GLABRA (WHITE TURTLEHEAD)
- EUPATORIADALPHUS DUBIUS (DWARF JOE PYE WEED)
- EUPATORIADALPHUS DUBIUS (DWARF JOE PYE WEED)
- EUPATORIADALPHUS FISTULOSUS (JOE PYE WEED)
- EUPATORIADALPHUS MACULATUS (SPOTTED TRUMPETWEED)
- HIBISCUS COCCINEUS (SCARLET ROSE MALLOW)
- HIBISCUS LAEVIS (HALBERDLEAF ROSEMALLOW)
- KOSTELETOZIA WIRGINICA (SCASHORE MALLOW)
- LOBELIA CAROLINAE (CARDINAL FLOWER)
- LOBELIA ELONGATA (LONGLEAF LOBELIA)
- LOBELIA SPHALTICA (GREAT BLUE LOBELIA)
- RHYNCHOSPORA COLORATA (STARBUSS WHITETOP)
- SACCHARUM BALDWINII (NARROW PLUMEGRASS)



LICENSE # C-2710
ENGINEERING
LAND PLANNING
COMMERCIAL / RESIDENTIAL

P.O. BOX 4041
WILMINGTON, NC 28406
(910) 791-4441

POND LANDSCAPING PLAN
PACIFIC PLACE

PACIFIC PLACE
LOCATED IN CITY OF WILMINGTON
NEW HANOVER COUNTY, NORTH CAROLINA

OWNER: ARYA HOLDINGS, LLC
PO BOX 3122
WILMINGTON, NC 28406

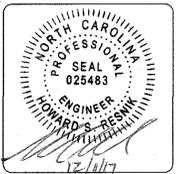

REV. NO.	DATE	BY	REMARKS
2	12/11/17	RLW	REVISION: EMERGENCY SPILLWAY LOCATION, ADDED CORN STAMPS
1	10/9/17	RLW	REVISION: POND

DATE: 8-3-17
HORZ SCALE: 1" = 10'
VERT. SCALE: N/A

DRAWN BY: RLW
CHECKED BY: HSR
PROJECT NO.: 17-0398